

ANALOG PWM IC

1. General Description

G1135P is a high performance offline PWM Power switch for low power AC/DC charger and adaptor applications up to 12W. It operates in primary-side regulation. Consequently, opto-coupler and TL431 could be eliminated.

Proprietary Constant Voltage (CV) and Constant Current (CC) control is integrated as shown in Fig.1. In CC control, the current and output power setting can be adjusted externally by the sense resistor R_S at CS pin. In CV control, multi-mode operations are utilized to achieve high performance and high efficiency.

In addition, good load regulation is achieved by the built-in cable drop compensation. Device operates in PFM in CC mode as well at large load condition and it operates in PWM with frequency reduction at light/medium load.

G1135P offers power on soft start control and protection coverage with auto-recovery features including Cycle-by-Cycle current limiting, VDD OVP, VDD clamp and UVLO. Excellent EMI performance is achieved with frequency jitter technique.

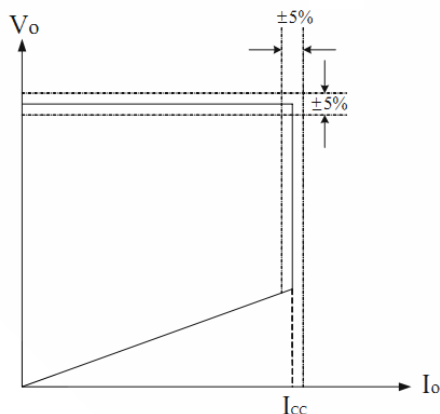

Fig.1. Typical CC/CV Curve

Features

- ◆ 5% CV and CC Regulation at Universal AC input
- ◆ Primary-side Regulation Without TL431 and Opto-coupler
- ◆ Built-in High-Voltage Power MOS
- ◆ Programmable CV and CC Regulation
- ◆ Adjustable Constant Current and Output Power Setting
- ◆ Built-in Secondary Constant Current Control with Primary Side Feedback
- ◆ Built-in Primary winding inductance compensation
- ◆ Programmable cable drop compensation
- ◆ Built-in Leading Edge Blanking (LEB)
- ◆ Power on Soft-start
- ◆ Built-in adaptive current peak regulation
- ◆ Cycle-by-Cycle Current Limiting
- ◆ VDD Under Voltage Lockout with Hysteresis (UVLO)
- ◆ VDD OVP and VDD Clamp
- ◆ Pb-free DIP-7

Applications

- ◆ Cell Phone Charger
- ◆ Digital Cameras Charger
- ◆ LED Driver
- ◆ Small Power Adaptor
- ◆ Auxiliary Power for PC, TV etc.
- ◆ Linear Regulator/RCC Replacement

G1135P is offered in DIP-7 package.

2. Products Information**2.1 Pin configuration**

Fig.2. G1135P Pin Configuration

Pin Name	I/O	Description
VDD	P	Power Supply
COMP	I	Loop Compensation for CV Stability
INV	I	The Voltage feedback from auxiliary winding. Connected to resistor divider from auxiliary winding reflecting output voltage. PWM duty cycle is determined by EA output and current sense signal at pin 4.
CS	I	Current sense input. Connected to primary current sensing resistor.
DRAIN	O	HV MOSFET Drain Pin. The Drain pin is connected to the primary lead of the transformer
GND	P	Ground

2.2 Output Power Table

Product	85~264VAC
	Adapter ¹
G1135P	12W

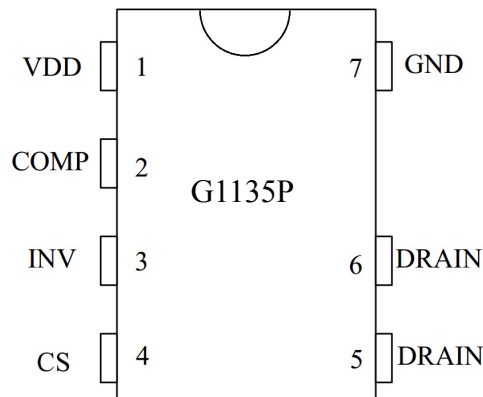
Notes:

1. Maximum practical continuous power in an Adapter design with sufficient drain pattern as a heat sink, at 50°C ambient. Higher output power is possible with extra added heat sink or air circulation to reduce thermal resistance.

2.3 Block diagram

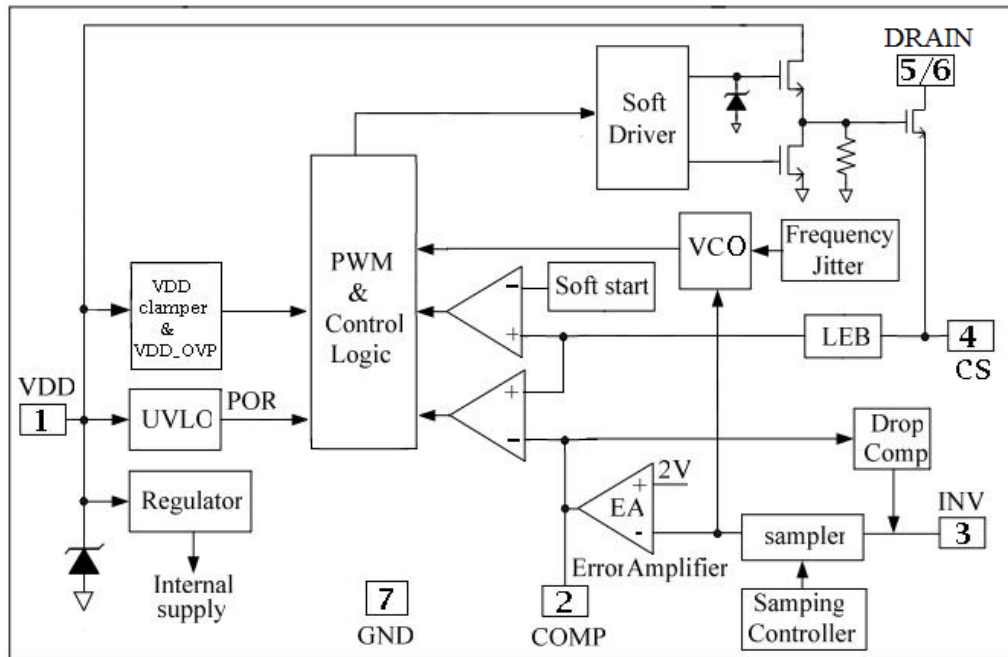

Fig.3. G1135P Block Diagram

3. Absolute Maximum Ratings

Description	Absolute Maximum Ratings
VDD Voltage	-0.3 to VDD_clamp
HV MOSFET Drain Voltage	-0.3 to BV _{dss}
VDD Zener Clamp Continuous Current	10 mA
COMP Voltage	-0.3 to 7V
CS Input Voltage	-0.3 to 7V
INV Input Voltage	-0.3 to 7V
Max Operating Junction Temperature T _J	150°C
Min/Max Storage Temperature T _{stg}	-55 to 150°C
Lead Temperature (Soldering, 10secs)	260°C
Package Dissipation Rating R _{θJA} ²	75°C/W

Notes:

- Stress beyond those listed under “absolute maximum ratings” may cause permanent damage to the device. Exposure to absolute maximum-rated conditions for extended periods may affect device reliability
- Drain Pin Connected to 100mm² PCB copper clad.

4. Electrical Characteristics

(TA = 25°C, VDD=16V, unless otherwise noted)

Symbol	Parameter	Test Conditions	Min	Typ	Max	Unit
Supply Voltage						
I _{VDD_ST}	Standby current	VDD=13V	--	3.5	20.0	μA
I _{VDD_OP}	Operation Current	INV=2V,CS=0V, VDD =20V	--	0.9	1.5	mA
UVLO_ON	VDD Under Voltage Lockout Enter	VDD falling	8.0	9.0	10.0	V
UVLO_OFF	VDD Under Voltage Lockout Exit	VDD rising	13.5	14.5	16.0	V
OVP	Over voltage protection voltage	Ramp up VDD until gate clock is off	27.0	28.0	29.0	V
VDD_Clamp	Maximum VDD operation voltage	IDD=10mA	32.0	33.5	35.0	V
Current Sense						
T _{LEB}	LEB time	--	--	500	--	ns
V _{TH_OC}	Over current threshold	--	980	1000	1020	mV
Z _{SENSE_IN}	Input Impedance	--	100	--	--	KΩ
T _{SS}	Soft start time	--	--	10	--	mS
Frequency Section						
Freq_Max ¹	System Nominal switch frequency	--	55	60	65	KHz
Freq_startup	--	INV=0V,Comp=5V	--	22	--	KHz
Δf/Freq	Frequency jitter range	--	--	+/-5	--	%
Error Amplifier Section						
Vref_EA	Reference voltage for EA	--	1.98	2.00	2.02	V
Gain	DC gain of the EA	--	--	60	--	dB
I _{COMP_Max}	Max. Cable compensation current	INV=2V,COMP=0V	--	42	--	μA
Power MOS Section						
BV _{dss}	MOSFET Drain-Source Breakdown Voltage	--	650	--	--	V
R _{dson}	On Resistance	--	--	4.4	--	Ω

Notes:

1. Freq_Max indicates IC internal maximum clock frequency. In system application, the maximum operation frequency of 60KHz nominal occurs at maximum output power or the transition point from CV to CC.



5. CHARACTERIZATION

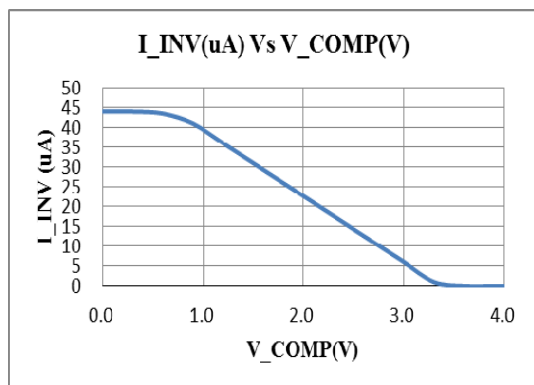
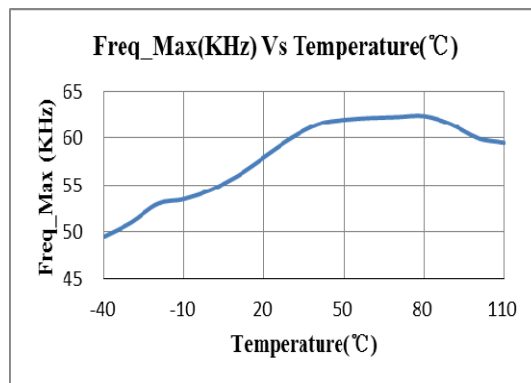
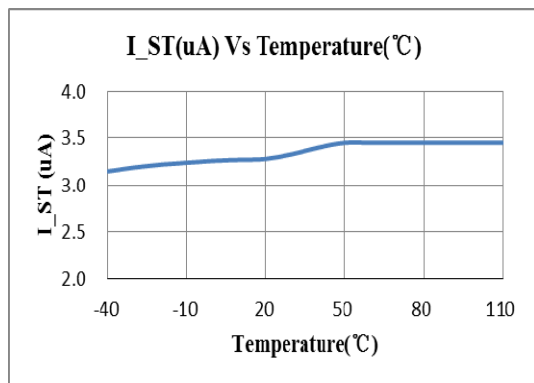
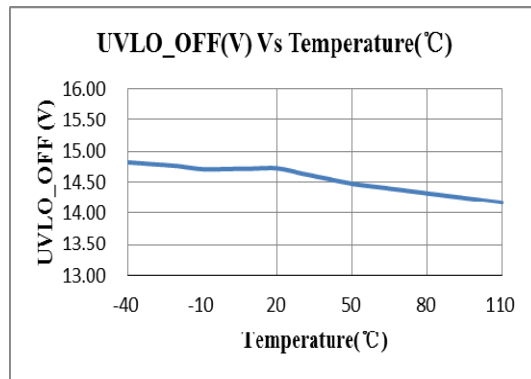
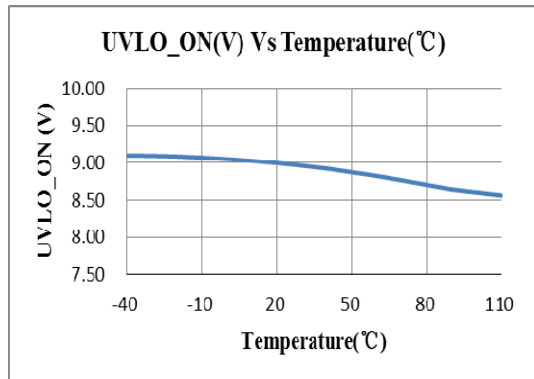

6. OPERATION DESCRIPTION

Fig.4. G1135P Typical Application

G1135P is a cost effective PWM power switch optimized for off-line low power AC/DC applications including battery chargers and adaptors. It operates in primary side sensing and regulation, thus opto-coupler and TL431 are not required. Proprietary built-in CV and CC control can achieve high precision CC/CV control meeting most adaptor and charger application requirements.

6.1 Startup Current and Start up Control

Startup current of G1135P is designed to be very low so that VDD could be charged up above UVLO threshold and starts up quickly. A large value startup resistor can therefore be used to minimize the power loss in application.

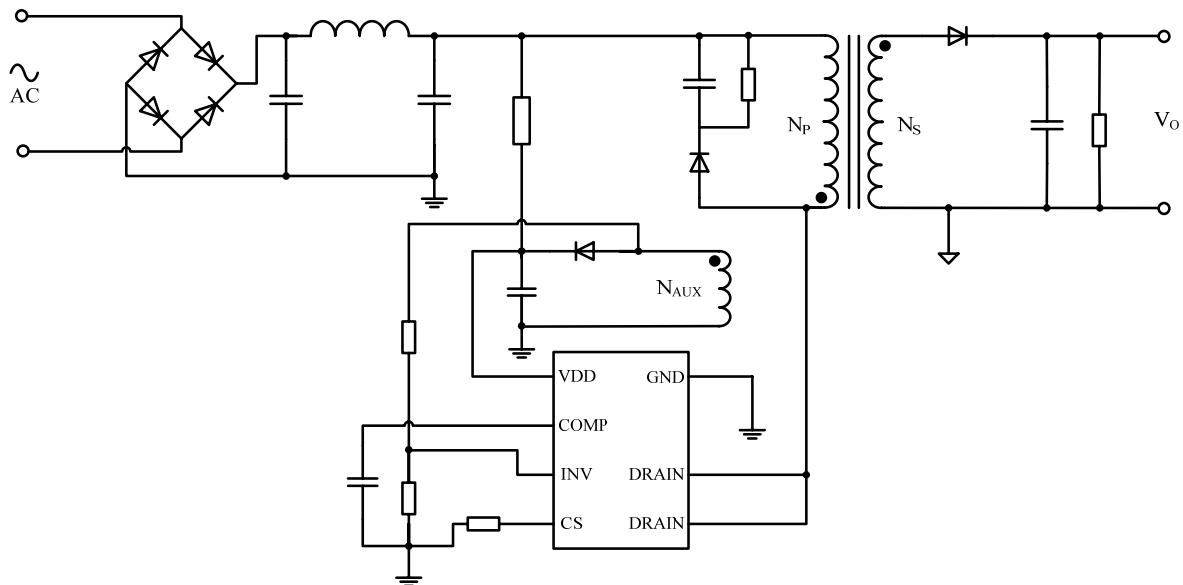
6.2 Operating Current

The Operating current of G1135P is as low as 0.9mA. Good efficiency is achieved with the low operating current together with Multi-mode control features.

6.3 Soft Start

G1135P features an internal soft start to minimize the component electrical over-stress during power on startup. As soon as VDD reaches UVLO (OFF), the control algorithm will ramp peak current voltage threshold gradually from nearly zero to normal setting of 1.00V. Every restart is a soft start.

6.4 CC/CV Operation

G1135P is designed to produce good CC/CV control characteristic as shown in the Fig.1. In charger applications, a discharged battery charging starts in the CC portion of the curve until it is nearly full charged and smoothly switches to operate in CV portion of the curve.

In an AC/DC adapter, the normal operation occurs only on the CV portion of the curve. The CC portion provides output current limiting. In CV operation, the output voltage is regulated through the primary side control. In CC operation mode, G1135P will regulate the output current constant regardless of the output voltage drop.

6.5 Principle of Operation

To support G1135P proprietary CC/CV control, system needs to be designed in DCM mode for flyback system (Refer to Fig.4). In the DCM flyback converter, the output voltage can be sensed via the auxiliary winding. During MOSFET turn-on time, the load current is supplied from the output filter capacitor C_O . The current in the primary winding ramps up. When MOSFET turns off, the primary current transfers to the secondary at the amplitude of

$$I_S = \frac{N_P}{N_S} \times I_P \quad (1)$$

The auxiliary voltage reflects the output voltage as shown in fig.5 and it is given by

$$V_{AUX} = \frac{N_{AUX}}{N_S} \times (V_O + \Delta V) \quad (2)$$

Where ΔV indicates the drop voltage of the output Diode.

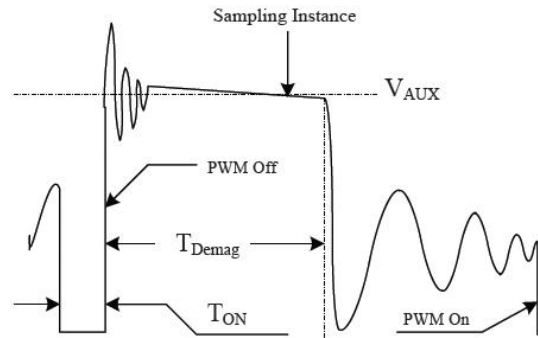

Fig.5. Auxiliary voltage waveform

Via a resistor divider connected between the auxiliary winding and INV (pin 3), the auxiliary voltage is sampled at the end of the demagnetization and it is hold until the next sampling.

The sampled voltage is compared with V_{ref} (2.0V) and the error is amplified. The error amplifier output COMP reflects the load condition and controls the PWM switching frequency to regulate the output voltage, thus constant output voltage can be achieved.

When sampled voltage is below V_{ref} and the error amplifier output COMP reaches its maximum, the switching frequency is controlled by the sampled voltage thus the output voltage to regulate the output current, thus the constant output current can be achieved.

6.6 Adjustable CC point and Output Power

In G1135P, the CC point and maximum output power can be externally adjusted by external current sense resistor R_S at CS pin as illustrated in Typical Application Diagram. The output power is adjusted through CC point change. The larger R_S , the smaller CC

point is, and the smaller output power becomes, and vice versa as shown in Fig.6.

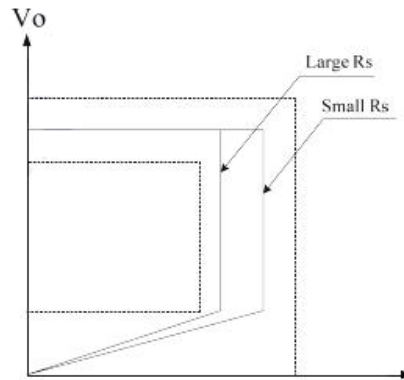

Fig.6. Adjustable output power by changing R_s

6.7 Operation switching frequency

The switching frequency of G1135P is adaptively controlled according to the load conditions and the operation modes. No external frequency setting components are required. The operation switching frequency at maximum output power is set to 60 KHz internally.

For flyback operating in DCM, The maximum output power is given by

$$P_{O_Max} = \frac{1}{2} \times L_p \times f_{SW} \times I_p^2 \quad (3)$$

Where L_p indicates the inductance of primary winding and I_p is the peak current of primary winding. Refer to the equation 3, the change of the primary winding inductance results in the change of the maximum output power and the constant output current in CC mode. To compensate the change from variations of primary winding inductance, the switching frequency is locked by an internal loop such that the switching frequency is

$$f_{SW} = \frac{1}{2 \times T_{demag}} \quad (4)$$

Since T_{demag} is inversely proportional to the inductance, as a result, the product L_p and f_{SW} is constant, thus the maximum output power and constant current in CC mode will not change as primary winding inductance changes. Up to +/-10% variation of the primary winding inductance can be compensated.

6.8 Frequency jitter for EMI improvement

The frequency jitter (switching frequency modulation) is implemented in G1135P. The oscillation frequency is modulated so that the tone energy is spread out. The spread spectrum minimizes the conduction band EMI and therefore eases the system design.

6.9 Current Sensing and Leading Edge Blanking

Cycle-by-Cycle current limiting is offered in G1135P current mode PWM control. The switch current is detected by a sense resistor into the CS pin. An internal leading edge blanking circuit chops off the sensed voltage spike at initial internal power MOSFET on state so that the external RC filtering on sense input is no longer needed. The PWM duty cycle is determined by the current sense input voltage and the EA output voltage.

6.10 Programmable Cable drop Compensation

In G1135P, cable drop compensation is implemented to achieve good load regulation. An offset voltage is generated at INV by an internal current flowing into the resistor divider. The current is inversely proportional to the voltage across pin COMP, as a result, it is inversely proportional to the output load current, thus the drop due to the cable loss can be compensated. As the load current decreases from full-load to no-load, the offset voltage at INV will increase. It can also be programmed by adjusting the resistance of the divider to compensate the drop for various cable lines used.

6.11 Protection Control

Good power supply system reliability is achieved with its rich protection features including Cycle-by-Cycle current limiting (OCP), VDD clamp, Power on Soft Start, and Under Voltage Lockout on VDD (UVLO). VDD is supplied by transformer auxiliary winding output. The output of G1135P is shut down when VDD drops below UVLO (ON) limit and Switcher enters power on start-up sequence thereafter.

G1135P

High Precision CC/CV Primary-Side PWM Power Switch

7. Package Information

DIP-7:

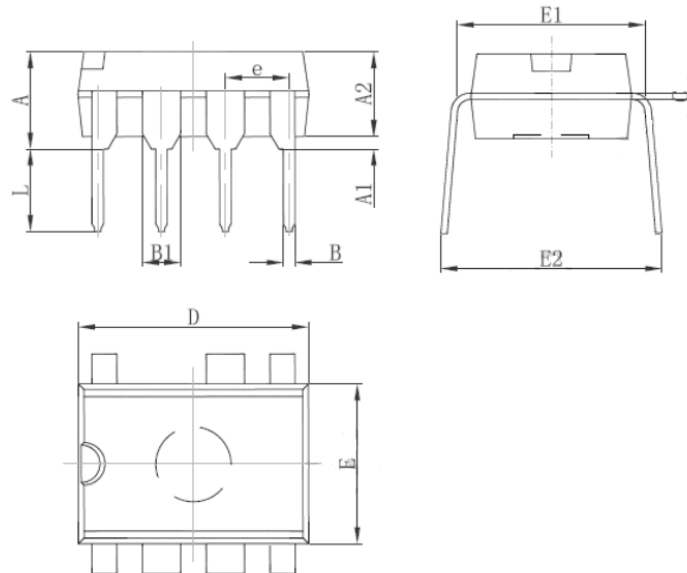

Symbol	Dimension in Millimeters		Dimensions in Inches	
	Min	Max	Min	Max
A	3.710	5.334	0.146	0.210
A1	0.381	--	0.015	--
A2	2.921	4.953	0.115	0.195
B	0.350	0.650	0.014	0.026
B1	1.524(BSC)		0.06(BSC)	
C	0.200	0.360	0.008	0.014
D	9.000	10.160	0.354	0.400
E	6.096	7.112	0.240	0.280
E1	7.320	8.255	0.288	0.325
e	2.540(BSC)		0.1(BSC)	
L	2.921	3.810	0.115	0.150
E2	7.620	10.920	0.300	0.430

Data and specifications subject to change without notice.

This product has been designed and qualified for Industrial Level and Lead-Free.

Qualification Standards can be found on GS's Web site.

Global Semiconductor HEADQUARTERS:

Scotia Centre, 4th Floor, P.O.Box 2804, George Town, Grand Cayman KY1-1112,
Cayman

Visit us at www.globalsemi-group.com for sales contact information.

