

# FSDH0170RNB/FSDH0270RNB/FSDH0370RNB Green Mode Fairchild Power Switch (FPS™)

## Features

- Internal Avalanche Rugged 700V Sense FET
- Consumes only 0.8W at 230 VAC & 0.5W load with Burst-Mode Operation
- Frequency Modulation for EMI Reduction
- Precision Fixed Operating Frequency, 100kHz
- Internal Start-up Circuit and Built-in Soft Start
- Pulse-by-Pulse Current Limiting and Auto-Restart Mode
- Over Voltage Protection (OVP), Over Load Protection (OLP), Internal Thermal Shutdown Function (TSD)
- Under Voltage Lockout (UVLO)
- Low Operating Current (3mA)
- Adjustable Peak Current Limit

## Applications

- Auxiliary Power Supply for PC and Server
- SMPS for VCR, SVR, STB, DVD & DVCD Player
- SMPS for Printer, Facsimile & Scanner
- Adapter for Camcorder

## Related Application Notes

- AN-4137, AN-4141, AN-4147 (Flyback)
- AN-4134 (Forward)

## Description

The FSDH0170RNB/FSDH0270RNB/FSDH0370RNB consists of an integrated current mode Pulse Width Modulator (PWM) and an avalanche rugged 700V Sense FET. It is specifically designed for high performance off-line Switch Mode Power Supplies (SMPS) with minimal external components. The integrated PWM controller features include : a fixed oscillator with frequency modulation for reduced EMI, Under Voltage Lock Out (UVLO) protection, Leading Edge Blanking (LEB), an optimized gate turn-on/turn-off driver, Thermal Shut Down (TSD) protection, and temperature compensated precision current sources for loop compensation and fault protection circuitry. Compared to a discrete MOSFET and controller or RCC switching converter solution, the FSDH0170RNB/FSDH0270RNB/FSDH0370RNB reduces total component count, design size, and weight while increasing efficiency, productivity, and system reliability. These devices provide a basic platform that is well suited for the design of cost-effective flyback converters, as in PC auxiliary power supplies.

## Ordering Information

Product Number	Package	Marking Code	BV <sub>DSS</sub>	f <sub>osc</sub>	R <sub>DS(ON)</sub> (MAX.)
FSDH0170RNB	8DIP	DH0170R	700V	100KHz	11Ω
FSDH0270RNB	8DIP	DH0270R	700V	100KHz	7.2Ω
FSDH0370RNB	8DIP	DH0370R	700V	100KHz	4.75Ω



## Pin Configuration

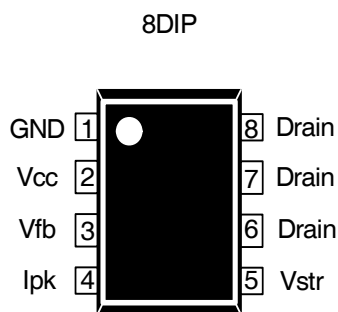

**Figure 3. Pin Configuration (Top View)**

## Pin Definitions

Pin Number	Pin Name	Pin Function Description
1	GND	Sense FET source terminal on primary side and internal control ground.
2	Vcc	Positive supply voltage input. Although connected to an auxiliary transformer winding, current is supplied from pin 5 (Vstr) via an internal switch during startup (see Internal Block Diagram Section). It is not until Vcc reaches the UVLO upper threshold (12V) that the internal start-up switch opens and device power is supplied via the auxiliary transformer winding.
3	Vfb	The feedback voltage pin is the non-inverting input to the PWM comparator. It has a 0.9mA current source connected internally while a capacitor and optocoupler are typically connected externally. A feedback voltage of 6V triggers overload protection (OLP). There is a time delay while charging external capacitor Cfb from 3V to 6V using an internal 5µA current source. This time delay prevents false triggering under transient conditions but still allows the protection mechanism to operate under true overload conditions.
4	lpk	This pin adjusts the peak current limit of the Sense FET. The 0.9mA feedback current source is diverted to the parallel combination of an internal 2.8kΩ resistor and any external resistor to GND on this pin. This determines the peak current limit. If this pin is tied to Vcc or left floating, the typical peak current limit will be 0.8A (FSDH0170RNB), 0.9A (FSDH0270RNB), or 1.1A (FSDH0370RNB).
5	Vstr	This pin connects to the rectified AC line voltage source. At start-up the internal switch supplies internal bias and charges an external storage capacitor placed between the Vcc pin and ground. Once the Vcc reaches 12V, the internal switch is opened.
6, 7, 8	Drain	The drain pins are designed to connect directly to the primary lead of the transformer and are capable of switching a maximum of 700V. Minimizing the length of the trace connecting these pins to the transformer will decrease leakage inductance.

## Absolute Maximum Ratings

( $T_A = 25^\circ\text{C}$ , unless otherwise specified)

Symbol	Parameter	Value	Unit	
$V_{\text{DRAIN}}$	Drain Pin Voltage	700	V	
$V_{\text{STR}}$	Vstr Pin Voltage	700	V	
$I_{\text{DM}}$	Drain Current Pulsed <sup>5</sup>	FSDH0170RNB	4	A
		FSDH0270RNB	8	A
		FSDH0370RNB	12	A
$E_{\text{AS}}$	Single Pulsed Avalanche Energy <sup>6</sup>	FSDH0170RNB	50	mJ
		FSDH0270RNB	140	mJ
		FSDH0370RNB	230	mJ
$V_{\text{CC}}$	Supply Voltage	20	V	
$V_{\text{FB}}$	Feedback Voltage Range	-0.3 to $V_{\text{CC}}$	V	
$P_{\text{D}}$	Total Power Dissipation	1.5	W	
$T_{\text{J}}$	Operating Junction Temperature	Internally limited	$^\circ\text{C}$	
$T_{\text{A}}$	Operating Ambient Temperature	-25 to +85	$^\circ\text{C}$	
$T_{\text{STG}}$	Storage Temperature	-55 to +150	$^\circ\text{C}$	

## Thermal Impedance

( $T_A = 25^\circ\text{C}$ , unless otherwise specified)

Symbol	Parameter	Value	Unit
<b>8 DIP</b>			
$\theta_{\text{JA}}$	Junction-to-Ambient Thermal <sup>7</sup>	80	$^\circ\text{C}/\text{W}$
$\theta_{\text{JC}}$	Junction-to-Case Thermal <sup>8</sup>	20	$^\circ\text{C}/\text{W}$
$\psi_{\text{JT}}$	Junction-to-Top Thermal <sup>9</sup>	35	$^\circ\text{C}/\text{W}$

All items are tested with the standards JESD 51-2 and 51-10 (DIP).

### Notes:

5. Non-repetitive rating; Pulse width is limited by maximum junction temperature.
6.  $L = 51\text{mH}$ , starting  $T_j = 25^\circ\text{C}$ .
7. Free standing with no heatsink; Without copper clad.
8. Measured on the DRAIN pin close to plastic interface.
9. Measured on the PKG top surface.

## Electrical Characteristics

( $T_A = 25^\circ\text{C}$  unless otherwise specified)

Symbol	Parameter	Condition	Min.	Typ.	Max.	Unit	
<b>Sense FET Section<sup>11</sup></b>							
$I_{DSS}$	Zero-Gate-Voltage Drain Current	$V_{DS} = 700\text{V}, V_{GS} = 0\text{V}$	–	–	50	$\mu\text{A}$	
		$V_{DS} = 560\text{V}, V_{GS} = 0\text{V}, T_C = 125^\circ\text{C}$	–	–	200		
$R_{DS(ON)}$	Drain-Source On-State Resistance <sup>10</sup>	$V_{GS} = 10\text{V}, I_D = 0.5\text{A}$	FSDH0170RNB	–	8.8	11	$\Omega$
			FSDH0270RNB	–	6.0	7.2	
			FSDH0370RNB	–	4.0	4.75	
$C_{ISS}$	Input Capacitance	$V_{GS} = 0\text{V}, V_{DS} = 25\text{V}, f = 1\text{MHz}$	FSDH0170RNB	–	250	–	$\text{pF}$
			FSDH0270RNB	–	550	–	
			FSDH0370RNB	–	315	–	
$C_{OSS}$	Output Capacitance		FSDH0170RNB	–	25	–	
			FSDH0270RNB	–	38	–	
			FSDH0370RNB	–	47	–	
$C_{RSS}$	Reverse Transfer Capacitance		FSDH0170RNB	–	10	–	
			FSDH0270RNB	–	17	–	
			FSDH0370RNB	–	9	–	
$t_{d(on)}$	Turn-On Delay Time	$V_{DS} = 350\text{V}, I_D = 1.0\text{A}$	FSDH0170RNB	–	12	–	ns
			FSDH0270RNB	–	20	–	
			FSDH0370RNB	–	11.2	–	
$t_r$	Rise Time		FSDH0170RNB	–	4	–	
			FSDH0270RNB	–	15	–	
			FSDH0370RNB	–	34	–	
$t_{d(off)}$	Turn-Off Delay Time		FSDH0170RNB	–	30	–	
			FSDH0270RNB	–	55	–	
			FSDH0370RNB	–	28.2	–	
$t_f$	Fall Time		FSDH0170RNB	–	10	–	
			FSDH0270RNB	–	25	–	
			FSDH0370RNB	–	32	–	
<b>Control Section</b>							
$f_{OSC}$	Switching Frequency		92	100	108	KHz	
$\Delta f_{MOD}$	Switching Frequency Modulation		$\pm 2$	$\pm 3$	$\pm 4$	KHz	
$\Delta f_{OSC}$	Switching Frequency Variation <sup>11</sup>	$-25^\circ\text{C} \leq T_A \leq 85^\circ\text{C}$	–	$\pm 5$	$\pm 10$	%	
$D_{MAX}$	Maximum Duty Cycle	Measured @0.1 x Vds	62	67	72	%	
$D_{MIN}$	Minimum Duty Cycle		0	0	0	%	
$V_{START}$	UVLO Threshold Voltage	$V_{FB} = \text{GND}$	11	12	13	V	
$V_{STOP}$		$V_{FB} = \text{GND}$	7	8	9		
$I_{FB}$	Feedback Source Current	$V_{FB} = \text{GND}$	0.7	0.9	1.1	mA	
$t_{S/S}$	Internal Soft Start Time <sup>11</sup>	$V_{FB} = 4\text{V}$	–	10	–	ms	

**Electrical Characteristics** (Continued)(T<sub>A</sub> = 25°C unless otherwise specified)

Symbol	Parameter	Condition	Min.	Typ.	Max.	Unit	
<b>Burst Mode Section</b>							
V <sub>BURH</sub>	Burst Mode Voltage	T <sub>j</sub> = 25°C	0.5	0.6	0.7	V	
V <sub>BURL</sub>			0.3	0.4	0.5	V	
V <sub>BUR(HYS)</sub>			100	200	300	mV	
<b>Protection Section</b>							
I <sub>LIM</sub>	Peak Current Limit	FSDH0170RNB	di/dt = 170mA/μs	0.70	0.80	0.90	A
		FSDH0270RNB	di/dt = 200mA/μs	0.79	0.90	1.01	
		FSDH0370RNB	di/dt = 240mA/μs	0.97	1.10	1.23	
t <sub>CLD</sub>	Current Limit Delay Time <sup>11</sup>		–	500	–	ns	
T <sub>SD</sub>	Thermal Shutdown Temperature <sup>11</sup>		125	140	–	°C	
V <sub>SD</sub>	Shutdown Feedback Voltage		5.5	6.0	6.5	V	
V <sub>OV</sub>	Over Voltage Protection		18	19	–	V	
I <sub>DELAY</sub>	Shutdown Delay Current	V <sub>FB</sub> = 4V	3.5	5.0	6.5	μA	
t <sub>LEB</sub>	Leading Edge Blanking Time <sup>11</sup>		200	–	–	ns	
<b>Total Device Section</b>							
I <sub>OP</sub>	Operating Supply Current (control part only)	V <sub>CC</sub> = 14V	1	3	5	mA	
I <sub>CH</sub>	Start-Up Charging Current	V <sub>CC</sub> = 0V	0.7	0.85	1.0	mA	
V <sub>STR</sub>	V <sub>str</sub> Supply Voltage	V <sub>CC</sub> = 0V	–	24	–	V	

**Notes:**

10. Pulse test : Pulse width ≤ 300μs, duty ≤ 2%

11. These parameters, although guaranteed, are not 100% tested in production.

## Typical Performance Characteristics (Control Part)

(These characteristic graphs are normalized at  $T_A = 25^\circ\text{C}$ )

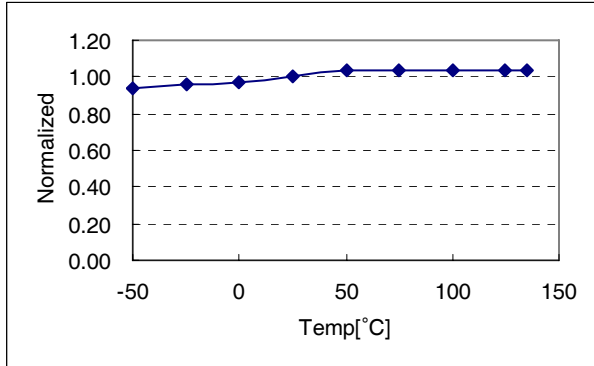

Operating Frequency ( $f_{osc}$ ) vs.  $T_A$

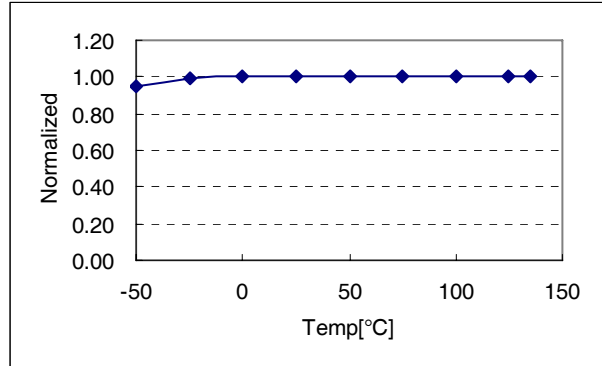

Frequency Modulation ( $\Delta f_{mod}$ ) vs.  $T_A$

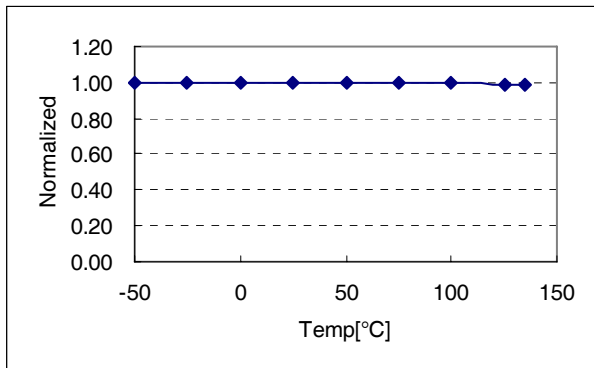

Maximum Duty Cycle ( $D_{MAX}$ ) vs.  $T_A$

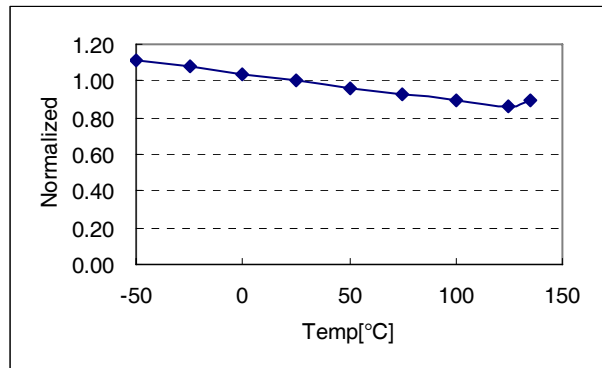

Operating Supply Current ( $I_{OP}$ ) vs.  $T_A$

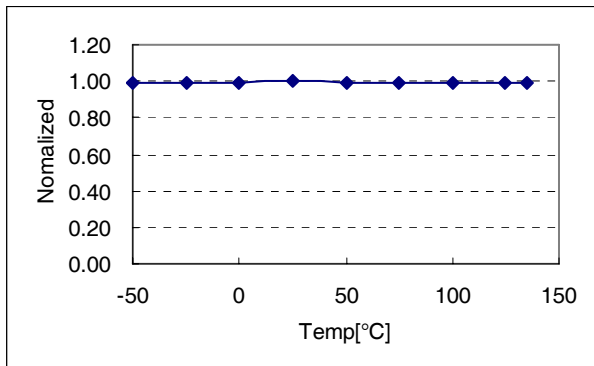

Start Threshold Voltage ( $V_{START}$ ) vs.  $T_A$

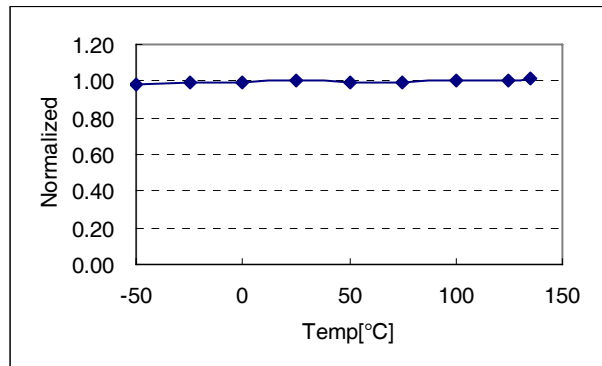

Stop Threshold Voltage ( $V_{STOP}$ ) vs.  $T_A$

### Typical Performance Characteristics (Continued)

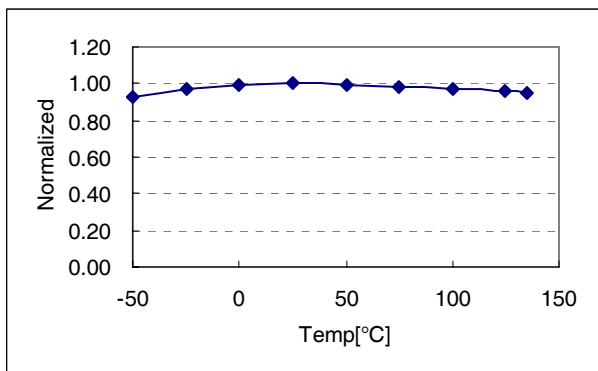

Feedback Source Current ( $I_{FB}$ ) vs.  $T_A$

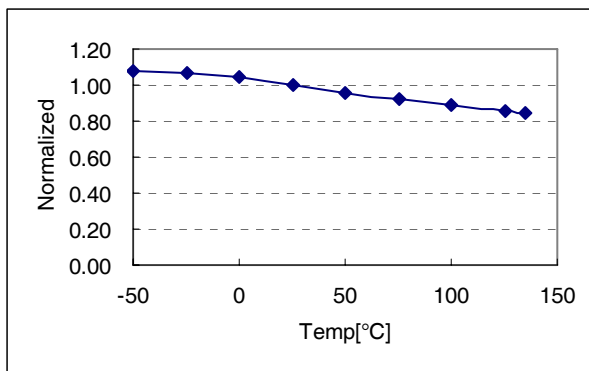

Start Up Charging Current ( $I_{CH}$ ) vs.  $T_A$

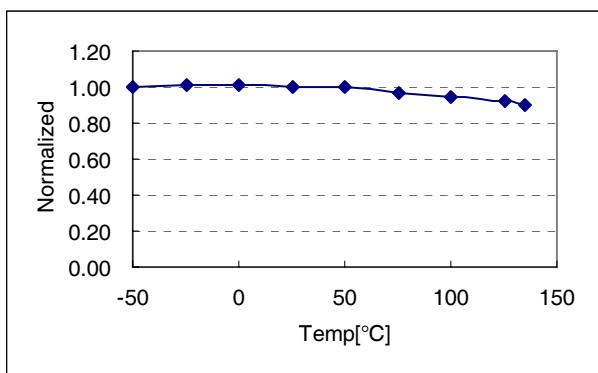

Peak Current Limit ( $I_{LIM}$ ) vs.  $T_A$

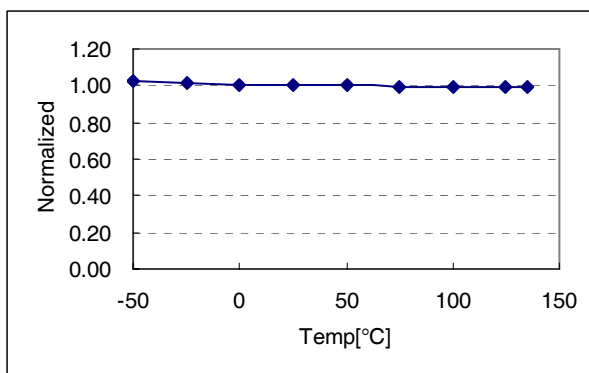

Over Voltage Protection ( $V_{OVP}$ ) vs.  $T_A$

## Functional Description

**1. Startup:** In previous generations of Fairchild Power Switches (FPS™) the  $V_{str}$  pin required an external resistor to the DC input voltage line. In this generation the startup resistor is replaced by an internal high voltage current source and a switch that shuts off 10ms after the supply voltage,  $V_{cc}$ , goes above 12V. The source turns back on if  $V_{cc}$  drops below 8V.

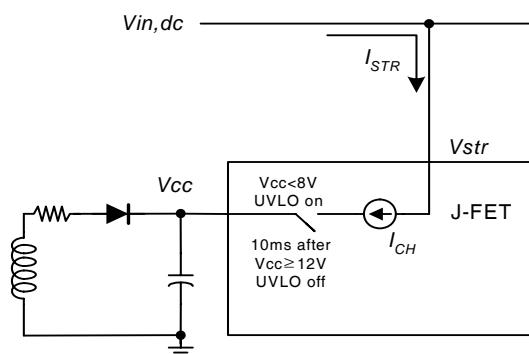

**Figure 4. High Voltage Current Source**

**2. Feedback Control:** The 700V FPS series employs current mode control, as shown in Figure 5. An optocoupler (such as the H11A817A) and shunt regulator (such as the KA431) are typically used to implement the feedback network. Comparing the feedback voltage with the voltage across the  $R_{sense}$  resistor of Sense FET plus an offset voltage makes it possible to control the switching duty cycle. When the KA431 reference pin voltage exceeds the internal reference voltage of 2.5V, the optocoupler LED current increases, the feedback voltage  $V_{fb}$  is pulled down and thereby reduces the duty cycle. This typically happens when the input voltage increases or the output load decreases.

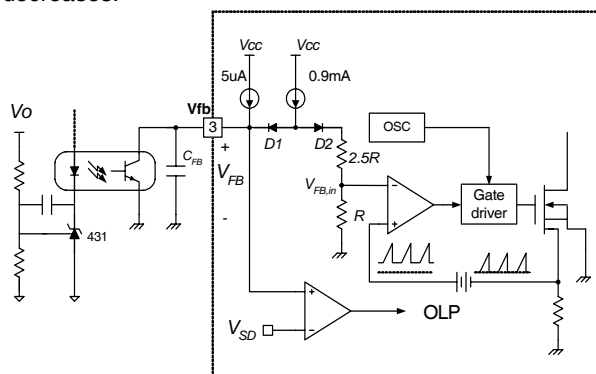
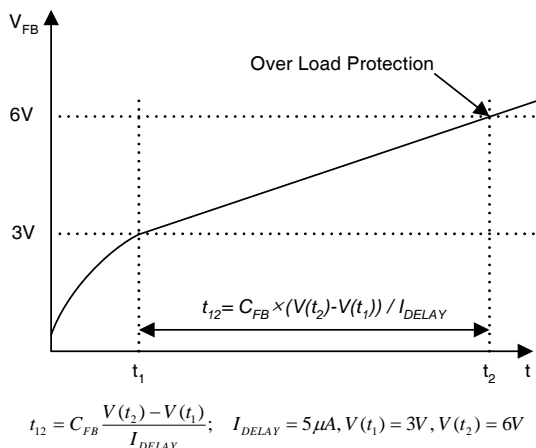

**Figure 5. Pulse Width Modulation (PWM) Circuit**

**3. Leading Edge Blanking (LEB):** When the internal Sense FET is turned on; the primary side capacitance and secondary side rectifier diode reverse recovery typically cause a high current spike through the Sense FET. Excessive voltage across the  $R_{sense}$  resistor leads to incorrect feedback operation in the current mode PWM control. To counter this effect, the FPS employs a Leading Edge Blanking (LEB) circuit. This circuit inhibits the PWM comparator for a short time ( $t_{LEB}$ ) after the Sense FET is turned on.

**4. Protection Circuits:** The FPS has several protective functions such as Over Load Protection (OLP), Over Voltage Protection (OVP), Under Voltage Lock Out (UVLO), and Thermal Shut Down (TSD). Because these protection circuits are fully integrated inside the IC without external components, reliability is improved without increasing cost. Once a fault condition occurs, switching is terminated and the Sense FET remains off. This causes  $V_{cc}$  to fall. When  $V_{cc}$  reaches the UVLO stop voltage,  $V_{STOP}$  (typically 8V), the protection is reset and the internal high voltage current source charges the  $V_{cc}$  capacitor via the  $V_{str}$  pin. When  $V_{cc}$  reaches the UVLO start voltage,  $V_{START}$  (typically 12V), the FPS resumes its normal operation. In this manner, the auto-restart can alternately enable and disable the switching of the power Sense FET until the fault condition is eliminated.

**4.1 Over Load Protection (OLP):** Overload is defined as the load current exceeding a pre-set level due to an unexpected event. In this situation, the protection circuit should be activated in order to protect the SMPS. However, even when the SMPS is operating normally, the Over Load Protection (OLP) circuit can be activated during the load transition. In order to avoid this undesired operation, the OLP circuit is designed to be activated after a specified time to determine whether it is a transient situation or an overload situation. In conjunction with the  $I_{pk}$  current limit pin (if used) the current mode feedback path would limit the current in the Sense FET when the maximum PWM duty cycle is attained. If the output consumes more than this maximum power, the output voltage ( $V_o$ ) decreases below its nominal voltage. This reduces the current through the optocoupler LED, which also reduces the feedback voltage ( $V_{FB}$ ). If  $V_{FB}$  exceeds 3V, the feedback input diode is blocked and the  $5\mu A$  current source ( $I_{DELAY}$ ) starts to slowly charge  $C_{fb}$  up to  $V_{cc}$ . In this condition,  $V_{FB}$  increases until it reaches 6V, when the switching operation is terminated as shown in Figure 6. The shutdown delay time is the time required to charge  $C_{fb}$  from 3V to 6V with  $5\mu A$  current source.

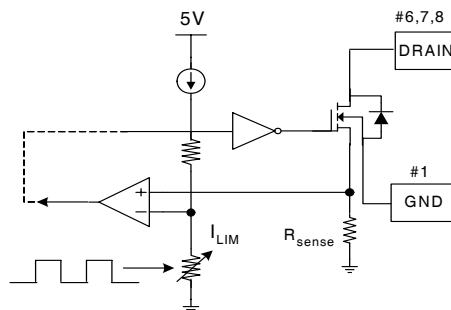

**Figure 6. Over Load Protection (OLP)**

**4.2 Thermal Shutdown (TSD):** The Sense FET and the control IC are integrated, making it easier for the control IC to detect the temperature of the Sense FET. When the temperature exceeds approximately 140°C, thermal shutdown is activated.

**4.3 Over Voltage Protection (OVP):** In the event of a malfunction in the secondary side feedback circuit, or an open feedback loop caused by a soldering defect, the current through the optocoupler transistor becomes almost zero (refer to Figure 5). Then,  $V_{FB}$  climbs up in a similar manner to the overload situation, forcing the preset maximum current to be supplied to the SMPS until the overload protection is activated. Because excess energy is provided to the output, the output voltage may exceed the rated voltage before the overload protection is activated, resulting in the breakdown of the devices in the secondary side. In order to prevent this situation, an Over Voltage Protection (OVP) circuit is employed. In general,  $V_{CC}$  is proportional to the output voltage and the FPS uses  $V_{CC}$  instead of directly monitoring the output voltage. If  $V_{CC}$  exceeds 19V, OVP circuit is activated resulting in termination of the switching operation. In order to avoid undesired activation of OVP during normal operation,  $V_{cc}$  should be designed to be below 19V.

**5. Soft Start:** The FPS has an internal soft start circuit that slowly increases the Sense FET current after startup as shown in Figure 7. The typical soft start time is 10ms, where progressive increments of the Sense FET current are allowed during the start-up phase. The pulse width to the power switching device is progressively increased to establish the correct working conditions for transformers, inductors, and capacitors. The voltage on the output capacitors is progressively increased with the intention of smoothly establishing the required output voltage. This also helps to prevent transformer saturation and reduce the stress on the secondary diode during startup.



**Figure 7. Soft Start Function**

**6. Burst Operation:** In order to minimize power dissipation in standby mode, the FPS enters burst mode operation. Feedback voltage decreases as the load decreases and as shown in Figure 8, the device automatically enters burst mode when the feedback voltage drops below  $V_{BURH}$  (typically 600mV). Switching still continues until the feedback voltage drops below  $V_{BURL}$  (typically 400mV). At this point switching stops and the output voltage start to drop at a rate dependent on the standby current load. This causes the feedback voltage to rise. Once it passes  $V_{BURH}$ , switching resumes. The feedback voltage then falls and the process is repeated. Burst mode operation alternately enables and disables switching of the Sense FET and reduces switching loss in standby mode.

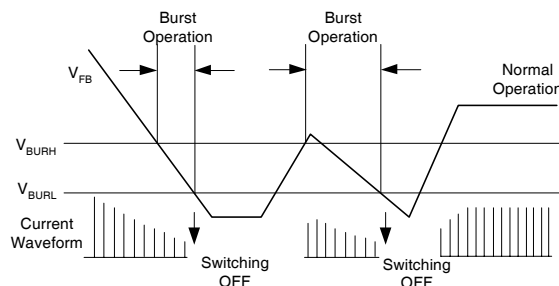

**Figure 8. Burst Operation Function**

**7. Frequency Modulation:** Modulating the switching frequency of a switched power supply can reduce EMI. Frequency modulation can reduce EMI by spreading the energy over a wider frequency range than the bandwidth measured by the EMI test equipment. The amount of EMI reduction is directly related to the depth of the reference frequency. As can be seen in Figure 9, the frequency changes from 97KHz to 103KHz in 4ms for the 700V FPS series. Frequency modulation allows the use of a cost effective inductor instead of an AC input mode choke to satisfy the requirements of world wide EMI limits.

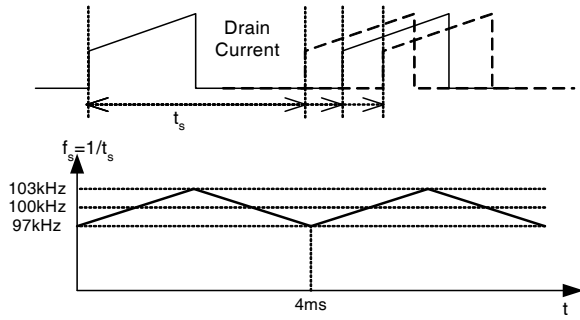

**Figure 9. Frequency Modulation Waveform**

**8. Adjusting Peak Current Limit:** As shown in Figure 10, a combined  $2.8\text{k}\Omega$  internal resistance is connected to the non-inverting lead on the PWM comparator. An external resistance of  $R_x$  on the current limit pin forms a parallel resistance with the  $2.8\text{k}\Omega$  when the internal diodes are biased by the main current source of  $900\mu\text{A}$ .

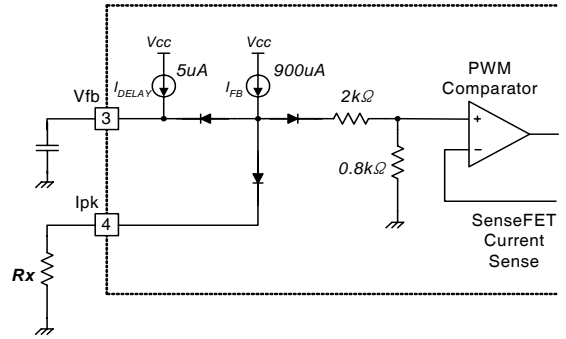

**Figure 10. Peak Current Limit Adjustment**

For example, FSDH0270RNB has a typical Sense FET peak current limit ( $I_{LIM}$ ) of  $0.9\text{A}$ .  $I_{LIM}$  can be adjusted to  $0.6\text{A}$  by inserting  $R_x$  between the lpk pin and the ground. The value of the  $R_x$  can be estimated by the following equations:

$$0.9\text{A} : 0.6\text{A} = 2.8\text{k}\Omega : X\text{k}\Omega,$$

$$X = R_x \parallel 2.8\text{k}\Omega.$$

(X represents the resistance of the parallel network)

## Application Tips

### 1. Methods of Reducing Audible Noise

Switching mode power converters have electronic and magnetic components, which generate audible noises when the operating frequency is in the range of 20~20,000Hz. Even though they operate above 20KHz, they can make noise depending on the load condition. Here are three methods to reduce noise:

#### Glue or Varnish

The most common method involves using glue or varnish to tighten magnetic components. The motion of core, bobbin, and coil and the chattering or magnetostriction of core can cause the transformer to produce audible noise. The use of rigid glue and varnish helps reduce the transformer noise. Glue or varnish can also crack the core because sudden changes in the ambient temperature cause the core and the glue to expand or shrink in a different ratio according to the temperature.

#### Ceramic Capacitor

Using a film capacitor instead of a ceramic capacitor as a snubber capacitor is another noise reduction solution. Some dielectric materials show a piezoelectric effect depending on the electric field intensity. Hence, a snubber capacitor becomes one of the most significant sources of audible noise. Another consideration is to use a zener clamp circuit instead of an RCD snubber for higher efficiency as well as lower audible noise.

#### Adjusting Sound Frequency

Moving the fundamental frequency of noise out of 2~4KHz range is the third method. Generally, humans are more sensitive to noise in the range of 2~4KHz. When the fundamental frequency of noise is located in this range, the noise sounds louder although the noise intensity level is identical. Refer to Figure 11.

When FPS acts in Burst mode and the Burst operation is suspected to be a source of noise, this method may be helpful. If the frequency of Burst mode operation lies in the range of 2~4KHz, adjusting the feedback loop can shift the Burst operation frequency. In order to reduce the Burst operation frequency, increase a feedback gain capacitor ( $C_F$ ), optocoupler supply resistor ( $R_D$ ) and feedback capacitor ( $C_B$ ) and decrease a feedback gain resistor ( $R_F$ ) as shown in Figure 12.

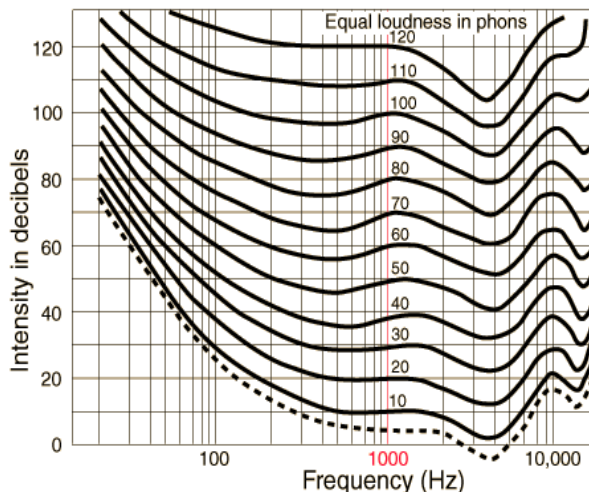

Figure 11. Equal Loudness Curves

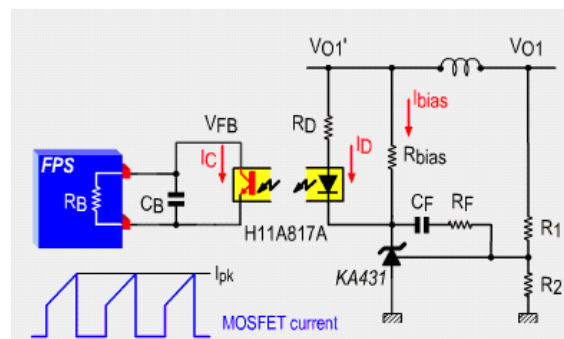

Figure 12. Typical Feedback Network of FPS

### 2. Other Reference Materials

**AN-4134:** Design Guidelines for Off-line Forward Converters Using Fairchild Power Switch (FPS™)

**AN-4137:** Design Guidelines for Off-line Flyback Converters Using Fairchild Power Switch (FPS)

**AN-4140:** Transformer Design Consideration for Off-line Flyback Converters using Fairchild Power Switch (FPS™)

**AN-4141:** Troubleshooting and Design Tips for Fairchild Power Switch (FPS™) Flyback Applications

**AN-4147:** Design Guidelines for RCD Snubber of Flyback

**AN-4148:** Audible Noise Reduction Techniques for FPS Applications

## Typical Application Circuit

Application	Output power	Input voltage	Output Voltage (Max current)
PC Auxiliary Power Supply (Using FSDH0270RNB)	15W	Universal input (85–265 Vac)	5V (3A)

### Features

- High efficiency (> 78% at 115 Vac and 230 Vac input)
- Low standby mode power consumption (< 0.8W at 230 Vac input and 0.5W load)
- Enhanced system reliability through various protection functions
- Low EMI through frequency modulation
- Internal soft-start (10ms)
- Line UVLO function can be achieved using external component

### Key Design Notes

- The delay time for overload protection is designed to be about 30ms with C8 of 47nF. If faster/slower triggering of OLP is required, C8 can be changed to a smaller/larger value (e.g. 100nF for about 60ms).
- ZP1, DL1, RL1, RL2, RL3, RL4, RL5, RL7, QL1, QL2, and CL9 build a Line Under Voltage Lock Out block (UVLO). The zener voltage of ZP1 determines the input voltage which makes FPS turn on. RL5 and DL1 provide a reference voltage from  $V_{CC}$ . If the input voltage divided by RL1, RL2, and RL4 is lower than the zener voltage of DL1, QL1 and QL2 turn on and pull down Vfb to ground.
- This evaluation board and corresponding test report can be provided.

1. Schematic

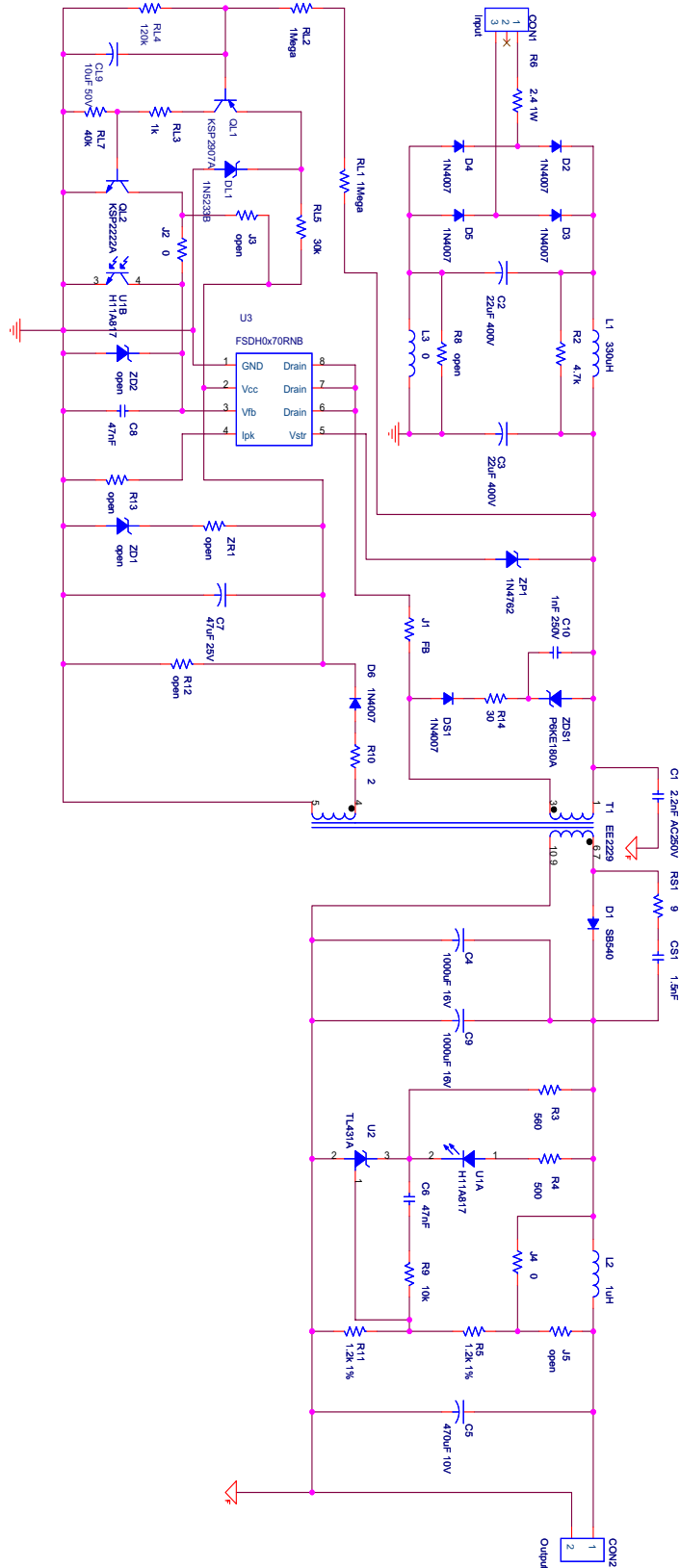

## 2. Transformer Schematic Diagram

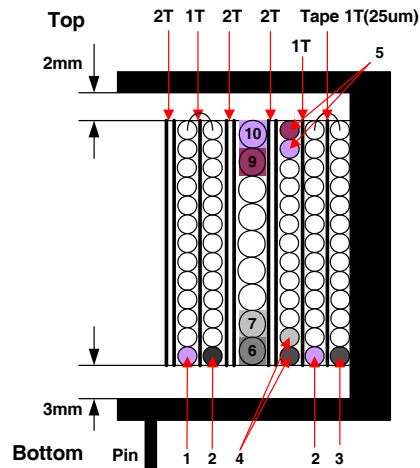
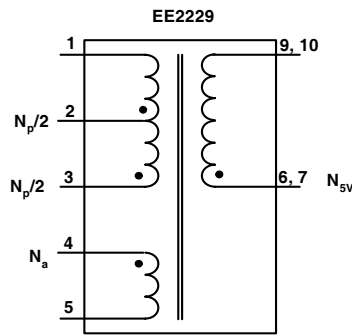

## 3. Winding Specification

	Pin (S → F)	Wire	Turns	Winding Method
$N_p/2$	3 → 2	$0.3\phi \times 1$	72	Solenoid winding
Insulation: Polyester Tape $t = 0.025\text{mm}$ , 1 Layers				
$N_a$	4 → 5	$0.25\phi \times 2$	22	Solenoid winding
Insulation: Polyester Tape $t = 0.025\text{mm}$ , 2 Layers				
$N_{5V}$	6, 7 → 9, 10	$0.65\phi \times 2$	8	Solenoid winding
Insulation: Polyester Tape $t = 0.025\text{mm}$ , 2 Layers				
$N_p/2$	2 → 1	$0.3\phi \times 1$	72	Solenoid winding
Insulation: Polyester Tape $t = 0.025\text{mm}$ , 2 Layers				

## 4. Electrical Characteristics

	Pin	Spec.	Remark
Inductance	1–3	$1.20\text{mH} \pm 5\%$	100kHz, 1V
Leakage	1–3	$< 30\mu\text{H Max}$	Short all other pins

## 5. Core & Bobbin

Core: EE2229 (Material: PL-7,  $A_e = 35.7 \text{ mm}^2$ )

Bobbin: 10 pin

## 6. Demo Circuit Part List

Part Number	Value	Quantity	Description (Manufacturer)
C6, C8	47nF	2	Ceramic Capacitor
C1	2.2nF (250V)	1	AC Ceramic Capacitor
C10	1nF (250V)	1	Film Capacitor
CS1	1.5nF (50V)	1	SMD Ceramic Capacitor
C2, C3	22 $\mu$ F (400V)	2	Low Impedance Electrolytic Capacitor KMX series (Samyoung Elec.)
C4, C9	1000 $\mu$ F (16V)	2	Low ESR Electrolytic Capacitor NXC series (Samyoung Elec.)
C5	470 $\mu$ F (10V)	1	Low ESR Electrolytic Capacitor NXC series (Samyoung Elec.)
C7	47 $\mu$ F (25V)	1	General Electrolytic Capacitor
CL9	10 $\mu$ F (50V)	1	General Electrolytic Capacitor
L1	330 $\mu$ H	1	Inductor
L2	1 $\mu$ H	1	Inductor
R6	2.4 (1W)	1	Fusible Resistor
J1	FB	1	Ferrite Beads
J2, J4, L3	0	3	Jumper
R2	4.7k	1	Resistor
R3	560	1	Resistor
R4	500	1	Resistor
R5, R11	1.2k(1%)	2	Resistor
R9	10k	1	Resistor
R10	2	1	Resistor
R14	30	1	Resistor
RL3	1k	1	Resistor
RL1, RL2	1 Mega	2	Resistor
RL4	120k	1	Resistor
RL5	30k	1	Resistor
RL7	40k	1	Resistor
RS1	9	1	Resistor
U1	H11A817	1	Optocoupler (Fairchild Semiconductor)
U2	TL431A	1	Shunt Regulator (Fairchild Semiconductor)
U3	FSDH0x70RNB	1	FPS™ (Fairchild Semiconductor)
QL1	KSP2907A	1	PNP Transistor (Fairchild Semiconductor)
QL2	KSP2222A	1	NPN Transistor (Fairchild Semiconductor)
D2, D3, D4, D5, D6, DS1	1N4007	6	Diode (Fairchild Semiconductor)
D1	SB540	1	Schottky Diode (Fairchild Semiconductor)
DL1	1N5233B	1	Zener Diode (Fairchild Semiconductor)
ZP1	1N4762	1	Zener Diode
ZDS1	P6KE180A	1	TVS (Fairchild Semiconductor)
T1	EE2229	1	PL-7 Core (Samwha Elec.)

## 7. Layout

### 7.1 Top image of PCB

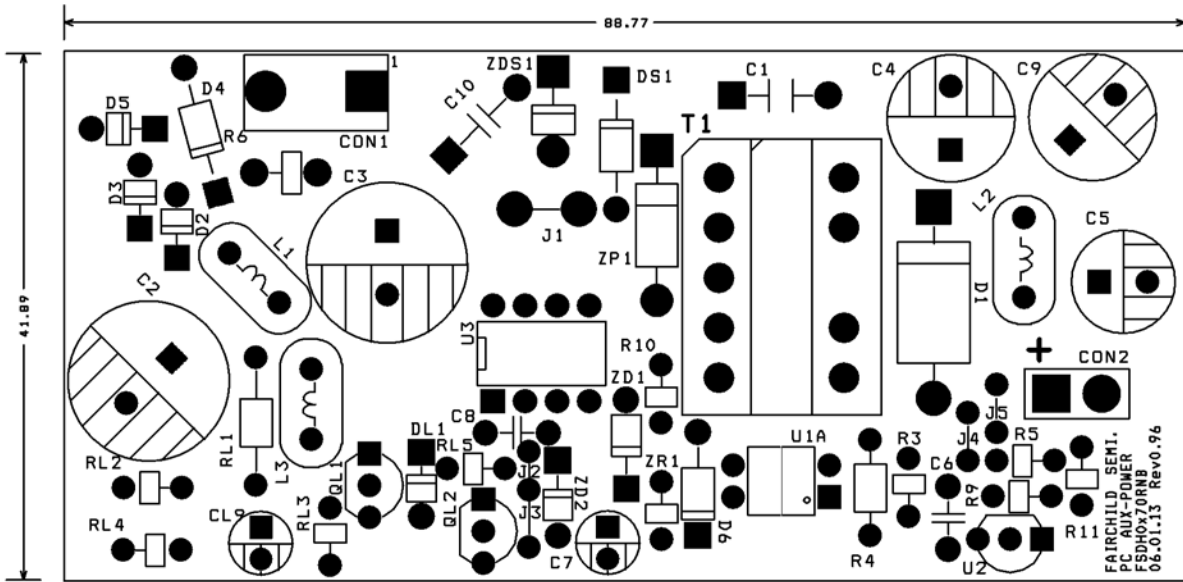

### 7.2 Bottom image of PCB

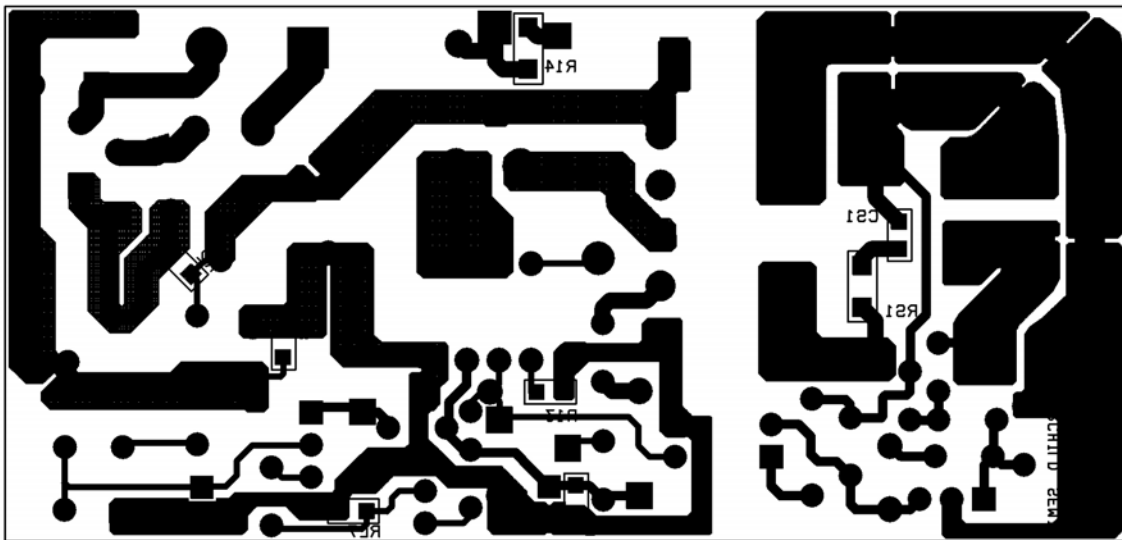

## Package Dimensions

8-Pin DIP

Dimensions in millimeters

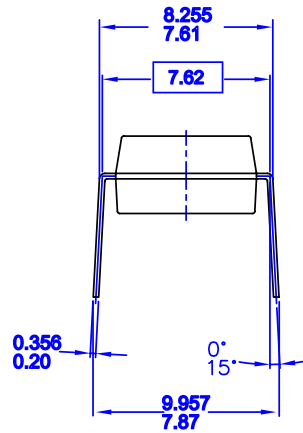
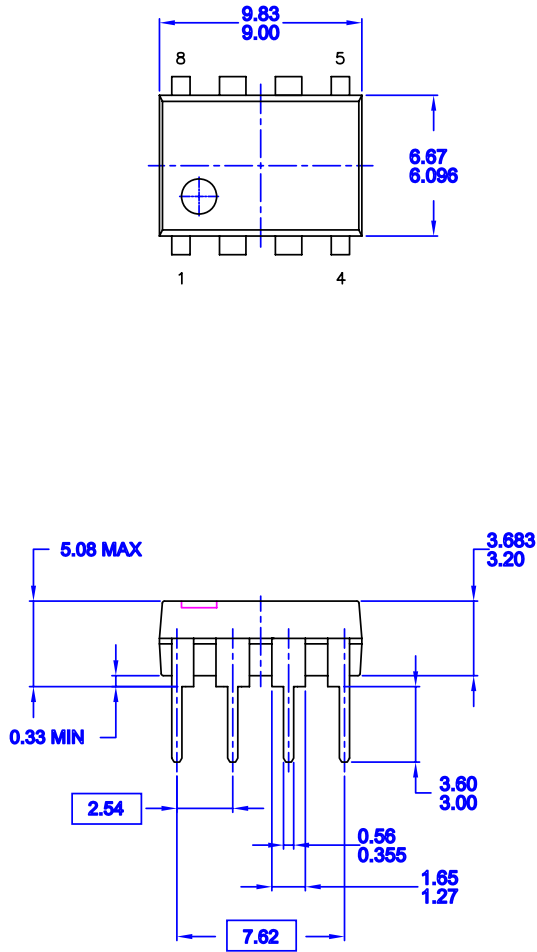

- NOTES: UNLESS OTHERWISE SPECIFIED**
- A) THIS PACKAGE CONFORMS TO JEDEC MS-001 VARIATION BA
  - B) ALL DIMENSIONS ARE IN MILLIMETERS.
  - C) DIMENSIONS ARE EXCLUSIVE OF BURRS, MOLD FLASH, AND TIE BAR EXTRUSIONS.
  - D) DIMENSIONS AND TOLERANCES PER ASME Y14.5M-1994

MKT-N08FrevB

## TRADEMARKS

The following are registered and unregistered trademarks Fairchild Semiconductor owns or is authorized to use and is not intended to be an exhaustive list of all such trademarks.

ACEx™	FAST®	ISOPLANAR™	PowerSaver™	SuperSOT™-6
ActiveArray™	FASTr™	LittleFET™	PowerTrench®	SuperSOT™-8
Bottomless™	FPS™	MICROCOUPLER™	QFET®	SyncFET™
Build it Now™	FRFET™	MicroFET™	QST™	TCM™
CoolFET™	GlobalOptoisolator™	MicroPak™	QT Optoelectronics™	TinyLogic®
CROSSVOLT™	GTO™	MICROWIRE™	Quiet Series™	TINYOPTO™
DOME™	HiSeC™	MSX™	RapidConfigure™	TruTranslation™
EcoSPARK™	I <sup>2</sup> C™	MSXPro™	RapidConnect™	UHC™
E <sup>2</sup> C MOS™	i-Lo™	OCX™	µSerDes™	UltraFET®
EnSigna™	ImpliedDisconnect™	OCXPro™	ScalarPump™	UniFET™
FACT™	IntelliMAX™	OPTOLOGIC®	SILENT SWITCHER®	VCX™
FACT Quiet Series™		OPTOPLANAR™	SMART START™	Wire™
Across the board. Around the world.™		PACMAN™	SPM™	
The Power Franchise®		POP™	Stealth™	
Programmable Active Droop™		Power247™	SuperFET™	
		PowerEdge™	SuperSOT™-3	

## DISCLAIMER

FAIRCHILD SEMICONDUCTOR RESERVES THE RIGHT TO MAKE CHANGES WITHOUT FURTHER NOTICE TO ANY PRODUCTS HEREIN TO IMPROVE RELIABILITY, FUNCTION OR DESIGN. FAIRCHILD DOES NOT ASSUME ANY LIABILITY ARISING OUT OF THE APPLICATION OR USE OF ANY PRODUCT OR CIRCUIT DESCRIBED HEREIN; NEITHER DOES IT CONVEY ANY LICENSE UNDER ITS PATENT RIGHTS, NOR THE RIGHTS OF OTHERS.

## LIFE SUPPORT POLICY

FAIRCHILD'S PRODUCTS ARE NOT AUTHORIZED FOR USE AS CRITICAL COMPONENTS IN LIFE SUPPORT DEVICES OR SYSTEMS WITHOUT THE EXPRESS WRITTEN APPROVAL OF FAIRCHILD SEMICONDUCTOR CORPORATION. As used herein:

1. Life support devices or systems are devices or systems which, (a) are intended for surgical implant into the body, or (b) support or sustain life, or (c) whose failure to perform when properly used in accordance with instructions for use provided in the labeling, can be reasonably expected to result in significant injury to the user.
2. A critical component is any component of a life support device or system whose failure to perform can be reasonably expected to cause the failure of the life support device or system, or to affect its safety or effectiveness.

## PRODUCT STATUS DEFINITIONS

### Definition of Terms

Datasheet Identification	Product Status	Definition
Advance Information	Formative or In Design	This datasheet contains the design specifications for product development. Specifications may change in any manner without notice.
Preliminary	First Production	This datasheet contains preliminary data, and supplementary data will be published at a later date. Fairchild Semiconductor reserves the right to make changes at any time without notice in order to improve design.
No Identification Needed	Full Production	This datasheet contains final specifications. Fairchild Semiconductor reserves the right to make changes at any time without notice in order to improve design.
Obsolete	Not In Production	This datasheet contains specifications on a product that has been discontinued by Fairchild semiconductor. The datasheet is printed for reference information only.

Rev. 118