

Current Mode PWM Controller**Description**

ICF CP2021 is a highly integrated current mode PWM control IC optimized for high performance, low standby power and cost effective offline flyback converter applications in sub 30W range.

PWM switching frequency at normal operation is externally programmable and trimmed to tight range. At no load or light load condition, the IC operates in extended 'burst mode' to minimize switching loss. Lower standby power and higher conversion efficiency is thus achieved. VDD low startup current and low operating current contribute to a reliable power on startup design with ICF CP2021. A large value resistor could thus be used in the startup circuit to minimize the standby power. The internal slope compensation improves system large signal stability and reduces the possible sub-harmonic oscillation at high PWM duty cycle output. Leading-edge blanking on current sense(CS) input removes the signal glitch due to snubber circuit diode reverse recovery and thus greatly reduces the external component count and system cost in the design.

ICF CP2021 offers complete protection coverage with automatic self-recovery feature including Cycle-by-Cycle current limiting (OCP), over load protection (OLP), VDD over voltage clamp and under voltage lockout (UVLO). The Gate-drive output is clamped to maximum 18V to protect the power MOSFET.

Excellent EMI performance is achieved with proprietary frequency shuffling technique together with soft switching control at the totem pole gate drive output.

Tone energy at below 20KHZ is minimized in the design and audio noise is eliminated during operation. ICF CP2021 is offered in SOT-23-6L, SOP-8 and DIP-8 packages.

Applications

Offline AC/DC flyback converter for

- Battery Charger
- Power Adaptor
- Set-Top Box Power Supplies
- Open-frame SMPS

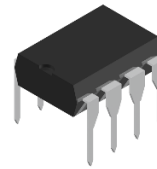
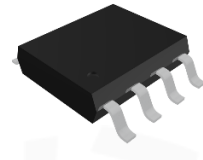
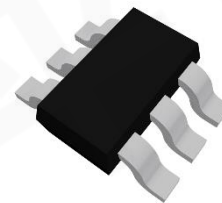
**DIP-8****SOP-8****SOT-23-6L****Features**

- Proprietary Frequency Shuffling Technology for Improved EMI Performance.
- Extended Burst Mode Control For Improved Efficiency and Minimum Standby Power Design
- Audio Noise Free Operation
- External Programmable PWM Switching Frequency
- Internal Synchronized Slope Compensation
- Low VDD Startup Current and Low Operating Current (1.8mA)
- Leading Edge Blanking on Current Sense Input
- Good Protection Coverage With Auto Self-Recovery:
 - VDD Over Voltage Clamp and Under Voltage Lockout with Hysteresis (UVLO)
 - Gate Output Maximum Voltage Clamp (18V)
 - Proprietary Line Input Compensated Cycle-by-Cycle Over-current Threshold Setting For Constant Output Power Limiting Over Universal Input Voltage Range.
 - Overload Protection (OLP)

Schematic diagram

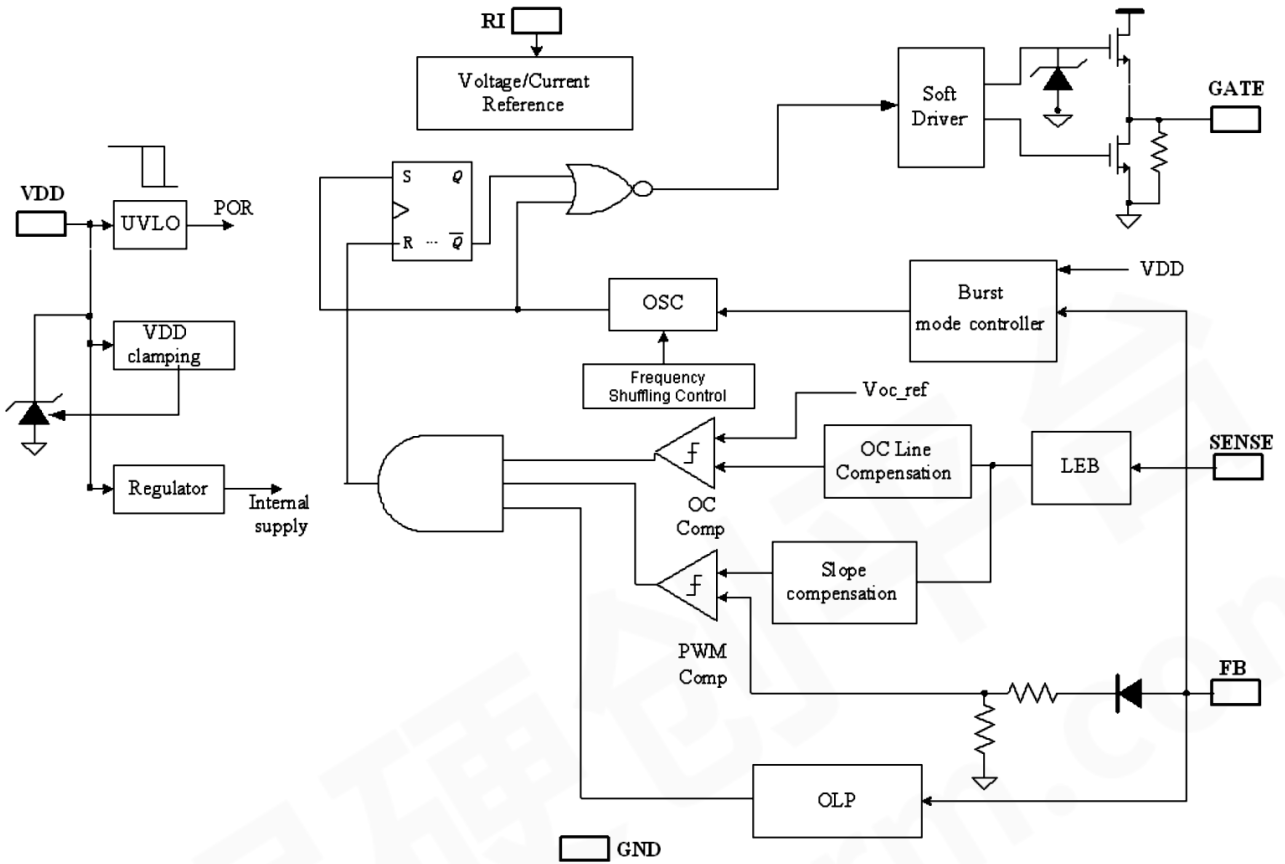

Figure 1 ICF CP2011 Schematic diagram

Pin configuration and description

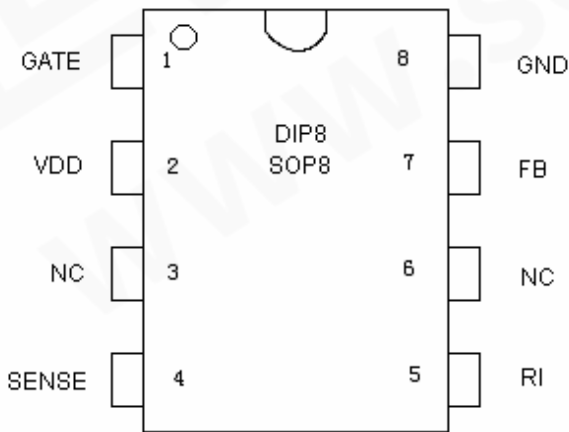

Figure 2 DIP-8/SOP-8

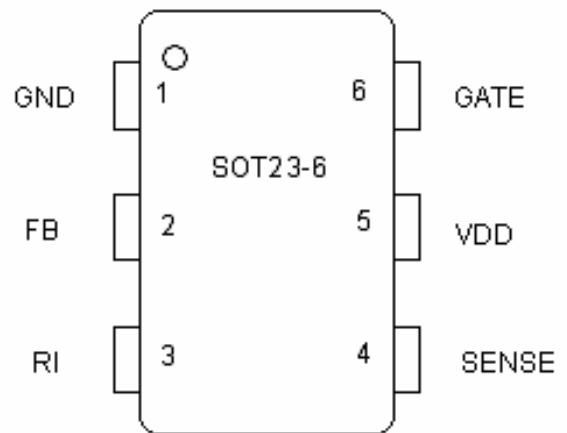

Figure 3 SOT-23-6L

NO.		Symbol	I/O	Description
DIP-8/ SOP-8	SOT-23- 6L			

1	6	GATE	O	Totem-pole gate drive output for the power MOSFET.
2	5	VDD	P	Chip DC power supply pin.
4	4	SENSE	I	Current sense input pin. Connected to MOSFET current sensing resistor node.
5	3	RI	I	Internal Oscillator frequency setting pin. A resistor connected between RI and GND sets the PWM frequency.
7	2	FB	I	Feedback input pin. The PWM duty cycle is determined by voltage level into this pin and SENSE pin input.
8	1	GND	P	Ground
3,6		NC		NC

Absolute maximum ratings ($T_A = 25^\circ\text{C}$, unless otherwise specified)

Parameter	Symbol	Value	Unit
VDD Supply Voltage	VDD	10 ~ 30	V
Input Voltage	V_{FB}	-0.3 ~ 7	V
Input Voltage to Sense Pin	V_{SENSE}	-0.3 ~ 7	V
Input Voltage to RI Pin	V_{RI}	-0.3 ~ 7	V
VDD DC Clamp Current	V_{CC}	10	mA
RI Resistor Value	RI	100	K Ω
Operating Temperature Range	T_{OPR}	-20 ~ +125	$^\circ\text{C}$
Storage Temperature Range	T_{STG}	-65 ~ +150	$^\circ\text{C}$

Electrical characteristics ($T_A = 25^\circ\text{C}$, unless otherwise specified)

Parameter	Symbol	Test conditions	Min	Typ	Max	Unit
Supply Voltage (VDD)						
VDD Start up Current	$I_{VDD_Start\ up}$	VDD =12.5V, RI=100K Ω Measure Leakage current into VDD		3	20	μA
Operation Current	I_{VDD_Ops}	VDD=16V, RI=100K Ω , $V_{FB}=3\text{V}$		1.8		mA
VDD Under Voltage Lockout Enter	UVLO(ON)		7.8	8.8	9.8	V
VDD Under Voltage Lockout Exit (Recovery)	UVLO(OFF)		13	14	15	V

VDD Zener Clamp Voltage	VDD_Clamp	$I_{VDD} = 5 \text{ mA}$		35		V
Feedback Input Section(FB Pin)						
PWM Input Gain	A_{VCS}	$\Delta V_{FB} / \Delta V_{CS}$		2.0		V/V
VFB Open Loop Voltage	V_{FB_Open}			5.4		V
FB pin short circuit current	I_{FB_Short}	Short FB pin to GND and measure current		1.6		mA
Zero Duty Cycle FB Threshold Voltage	V_{TH_OD}	VDD=16V, RI=100K Ω			1.2	V
Power Limiting FB Threshold Voltage	V_{TH_PL}			3.6		V
Power limiting De-bounce Time	T_{D_PL}			35		mS
Input Impedance	Z_{FB_IN}			6		K Ω
Maximum Duty Cycle	DC_MAX	VDD=18V, RI=100K Ω , FB=3V, CS=0		76		%
Current Sense Input(Sense Pin)						
Leading edge blanking time	$T_{blanking}$	RI = 100 K Ω		300		ns
Input Impedance	Z_{SENSE_IN}			40		K Ω
Over Current Detection and Control Delay	T_{D_OC}	VDD = 16V, CS> V_{TH_OC} , FB=3.3V		75		nS
Over Current Threshold Voltage at zero Duty Cycle	V_{TH_OC}	FB=3.3V, RI=100 K Ω	0.70	0.75	0.80	V
Oscillator						
Normal Oscillation Frequency	F_{OSC}	RI = 100 K Ω	60	65	70	KHz
Frequency Temperature Stability	Δf_{Temp}	VDD = 16V, RI=100K Ω , $T_A = -20^\circ\text{C} \sim +125^\circ\text{C}$		5		%
Frequency Voltage Stability	Δf_{VDD}	VDD = 12 V ~ 25V, RI=100K Ω		5		%
Operating RI Range	RI_range		50	100	150	K Ω
RI open load voltage	V_{RI_open}			2		V
Burst Mode Base Frequency	F_{osc_BM}	VDD = 16V, RI=100K Ω		22		KHz

Gate Drive Output						
Output Low Level	VOL	VDD = 16V, Io = - 20 mA			0.5	V
Output High Level	VOH	VDD = 16V, Io = 20 mA	11			V
Output Clamp Voltage Level	V_Clamp			18		V
Output Rising Time	T_r	VDD = 16V, CL = 1nf		220		nS
Output Falling Time	T_f	VDD = 16V, CL = 1nf		70		nS
Frequency Shuffling						
Frequency Modulation range /Base frequency	Δf_{OSC}	RI=100K Ω	-3		3	%
Shuffling Frequency	f_shuffling	RI=100K Ω		64		Hz

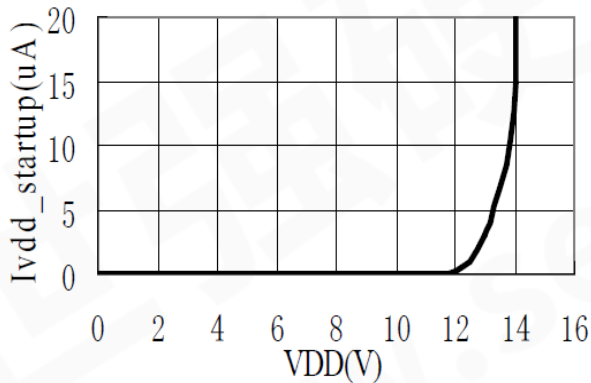
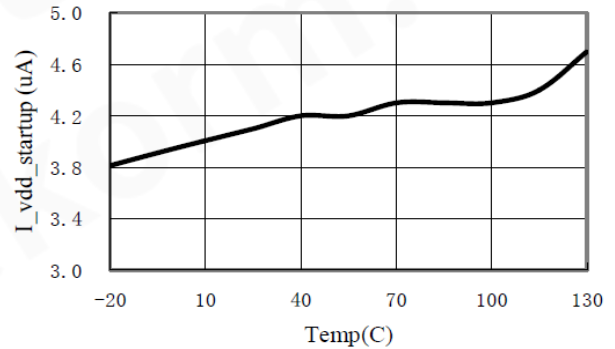
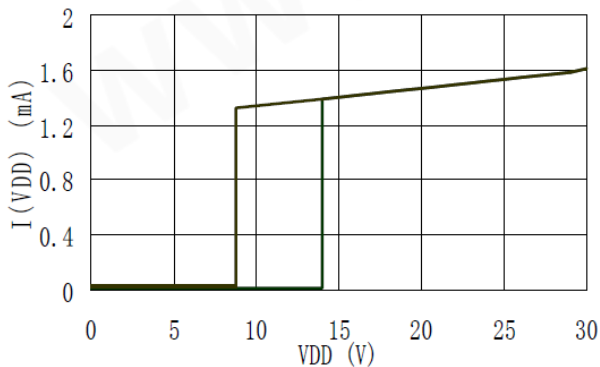
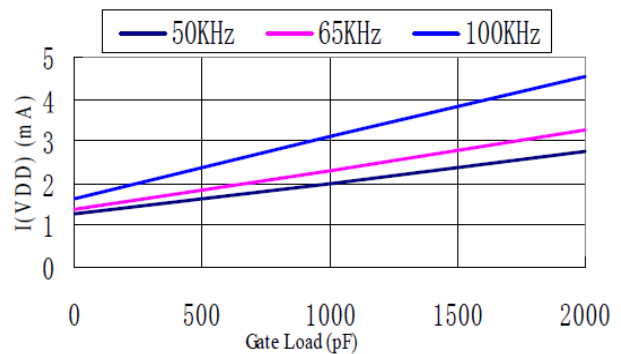
Electrical characteristic curves ($T_A = 25^\circ\text{C}$, VDD=16V, RI=100K, unless otherwise specified)

Figure 4 VDD Startup Current vs. Voltage

Figure 5 I_VDD_startup vs. Temp

Figure 6 VDD UVLO and Ops Current

Figure 7 VDD Operation Current vs. Load(pF)

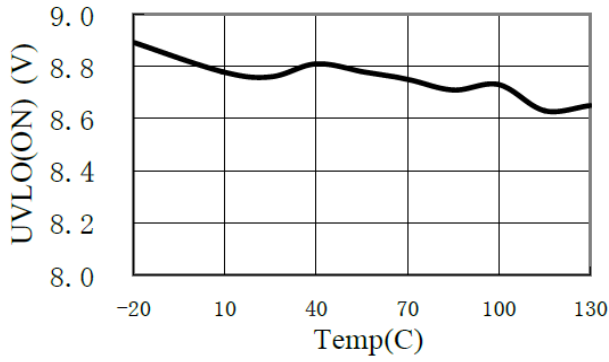

Figure 8 UVLO(ON) vs. Temp

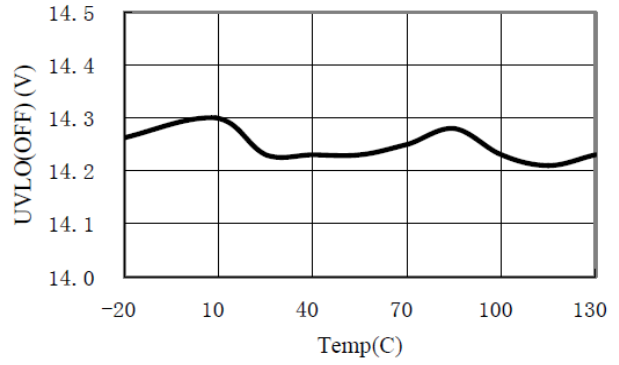

Figure 9 UVLO(OFF) vs. Temp

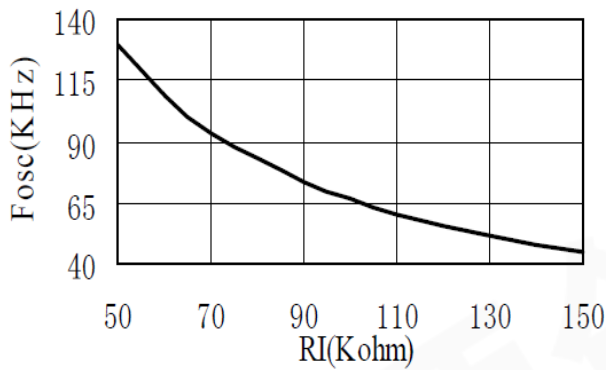

Figure 10 Fosc(KHz) vs. RI(Kohm)

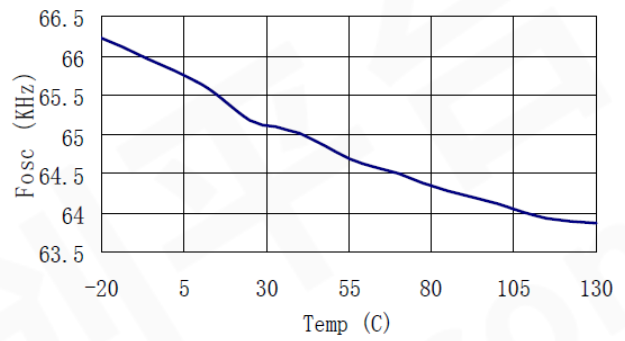

Figure 11 Fosc vs. Temp

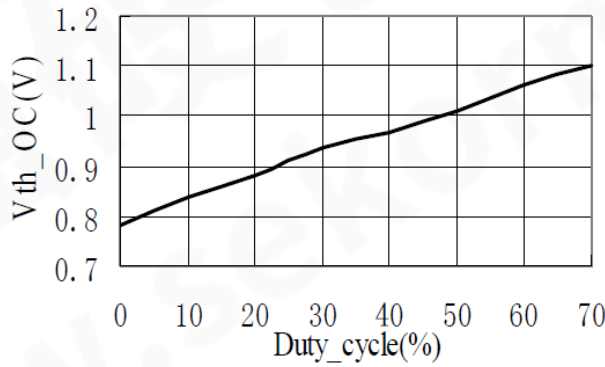

Figure 12 Vth_OC(V) vs Duty_cycle(%)

Typical applications

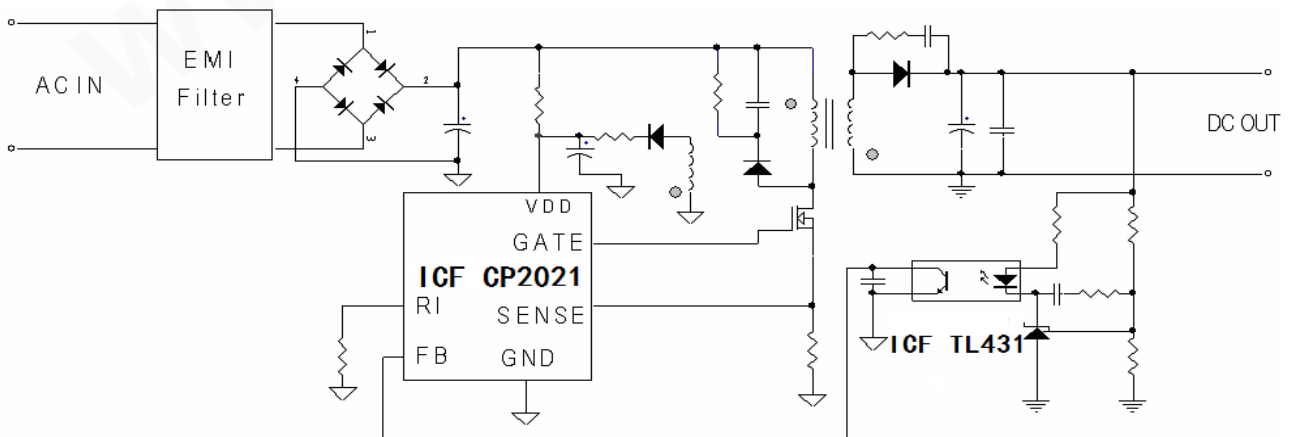

Figure 13 ICF CP2011 Typical application

Operation description

The ICF CP2021 is a highly integrated PWM controller IC optimized for offline flyback converter applications in sub 30W power range. The extended burst mode control greatly reduces the standby power consumption and helps the design easily meet the international power conservation requirements.

Startup Current and Start up Control

Startup current of ICF CP2021 is designed to be very low so that VDD could be charged up above UVLO threshold level and device starts up quickly. A large value startup resistor can therefore be used to minimize the power loss yet provides reliable startup in application. For AC/DC adaptor with universal input range design, a 2 MΩ, 1/8 W startup resistor could be used together with a VDD capacitor to provide a fast startup and low power dissipation solution.

Operating Current

The Operating current of ICF CP2021 is low at 1.8mA. Good efficiency is achieved with ICF CP2021 low operating current together with extended burst mode control features.

Frequency shuffling for EMI improvement

The frequency Shuffling/jittering (switching frequency modulation) is implemented in ICF CP2021. The oscillation frequency is modulated with a random source so that the tone energy is spread out. The spread spectrum minimizes the conduction band EMI and therefore reduces system design challenge.

Extended Burst Mode Operation

At zero load or light load condition, majority of the power dissipation in a switching mode power supply is from switching loss on the MOSFET transistor, the core loss of the transformer and the loss on the snubber circuit. The magnitude of power loss is in proportion to the number of switching events within a fixed period of time. Reducing switching events leads to the reduction on the power loss and thus conserves the energy.

ICF CP2021 self adjusts the switching mode according to the loading condition. At from no load to light/medium load condition, the FB input drops below burst mode threshold level. Device enters Burst Mode control. The Gate drive output switches only when VDD voltage drops below a preset level and FB input is active to output an on state. Otherwise the gate drive remains at off state to minimize the switching loss and reduces the standby power consumption to the greatest extend. The frequency control also eliminates the audio noise at any loading conditions.

Oscillator Operation

A resistor connected between RI and GND sets the constant current source to charge/discharge the internal cap and thus the PWM oscillator frequency is determined. The relationship between RI and switching frequency follows the below equation within the specified RI in Kohm range at nominal loading operational condition.

$$F_{OSC} \text{ (KHz)} = 6500 / RI$$

Current Sensing and Leading Edge Blanking

Cycle-by-Cycle current limiting is offered in ICF CP2021 current mode PWM control. The switch current is detected by a sense resistor into the sense pin. An internal leading edge blanking circuit chops off the sense voltage spike at initial MOSFET on state due to Snubber diode reverse recovery so that the external RC filtering on sense input is no longer required. The current limit comparator is disabled and thus cannot turn off the external MOSFET during the blanking period. PWM duty cycle is determined by the current sense input voltage and the FB input voltage.

Internal Synchronized Slope Compensation

Built-in slope compensation circuit adds voltage ramp onto the current sense input voltage for PWM generation. This greatly improves the close loop stability at CCM and prevents the sub-harmonic oscillation and thus reduces the output ripple voltage.

Gate Drive

ICF CP2021 Gate is connected to an external MOSFET gate for power switch control. Too weak the gate drive strength results in higher conduction and switch loss of MOSFET while too strong gate drive output compromises the EMI. A good tradeoff is achieved through the built-in totem pole gate design with right output strength and dead time control. The low idle loss and good EMI system design is easier to achieve with this dedicated control scheme. An internal 18V clamp is added for MOSFET gate protection at higher than expected VDD input.

Protection Controls

Good power supply system reliability is achieved with its rich protection features including Cycle-by- Cycle current limiting (OCP), Over Load Protection (OLP) and over voltage clamp, Under Voltage Lockout on VDD (UVLO).

With Proprietary technology, the OCP threshold tracks PWM Duty cycles and is line voltage compensated to achieve constant output power limit over the universal input voltage range with recommended reference design.

At overload condition when FB input voltage exceeds power limit threshold value for more than TD_PL, control circuit reacts to shut down the output power MOSFET. Device restarts when VDD voltage drops below UVLO limit.

VDD is supplied by transformer auxiliary winding output. It is clamped when VDD is higher than threshold value. The power MOSFET is shut down when VDD drops below UVLO limit and device enters power on start-up sequence thereafter.

Package information

DIP-8

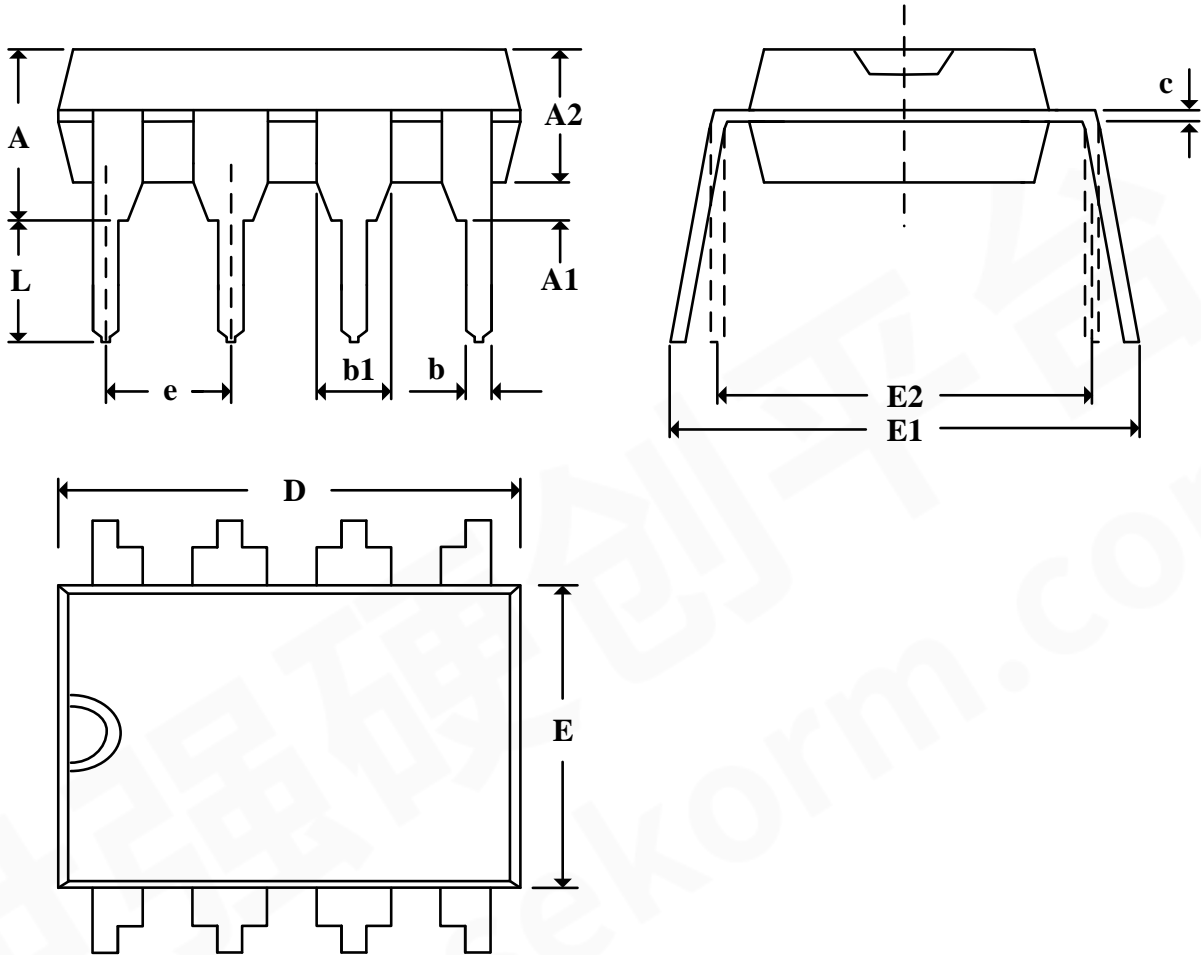

Symbol	Dimensions (mm)		Symbol	Dimensions (mm)	
	Min	Max		Min	Max
A	3.600	4.310	e	2.540 (BSC)	
A1	0.510		D	9.000	9.450
A2	3.000	3.600	E	6.150	6.600
b	0.330	0.530	E1	7.870	9.610
b1	1.520 (BSC)		E2	7.320	7.920
c	0.204	0.360	L	3.000	3.600

SOP-8

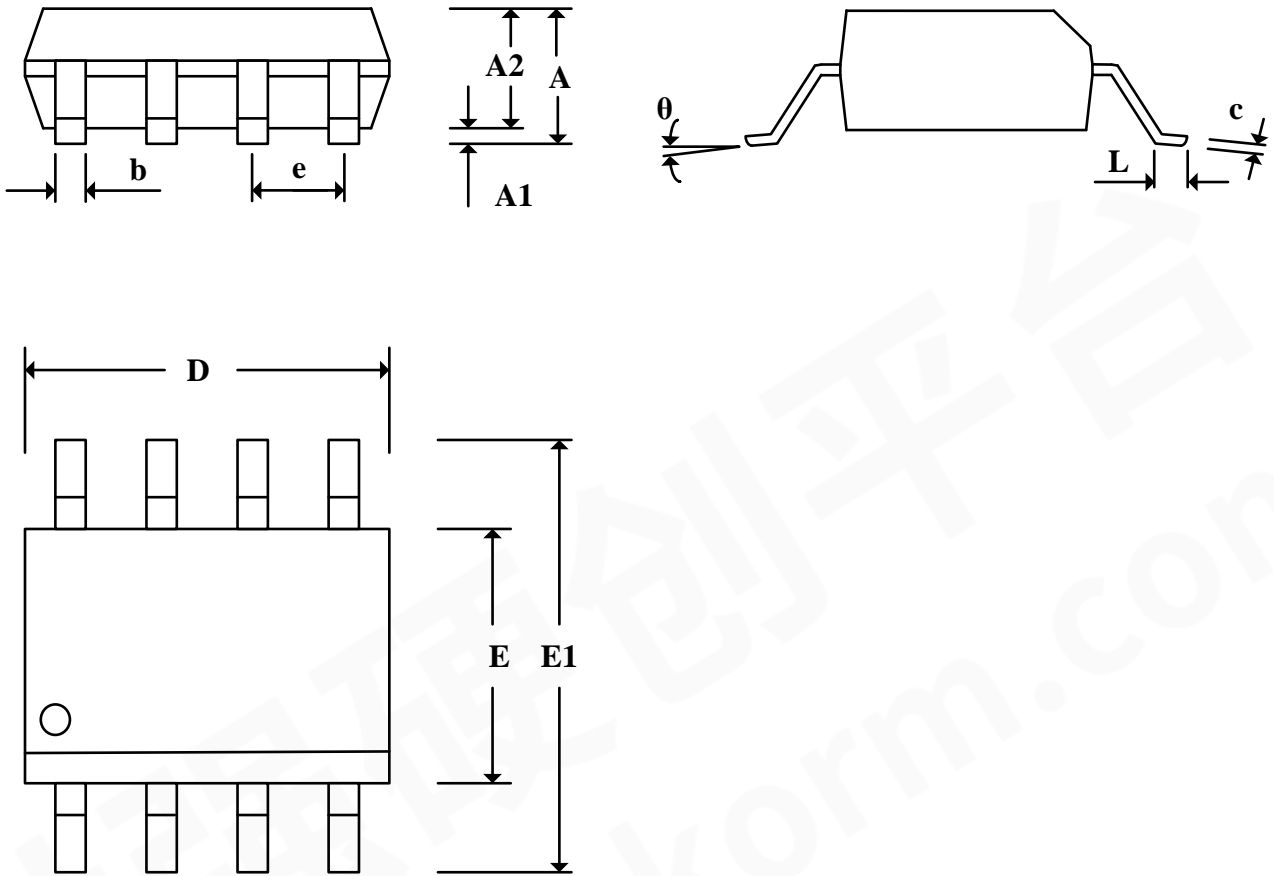

Symbol	Dimensions (mm)		Symbol	Dimensions (mm)	
	Min	Max		Min	Max
A	1.350	1.800	D	4.700	5.100
A1	0.100	0.250	E	3.700	4.100
A2	1.250	1.550	E1	5.800	6.300
b	0.330	0.510	L	0.400	0.800
c	0.190	0.250	θ	0°	8°
e	1.270 (BSC)				

SOT-23-6L

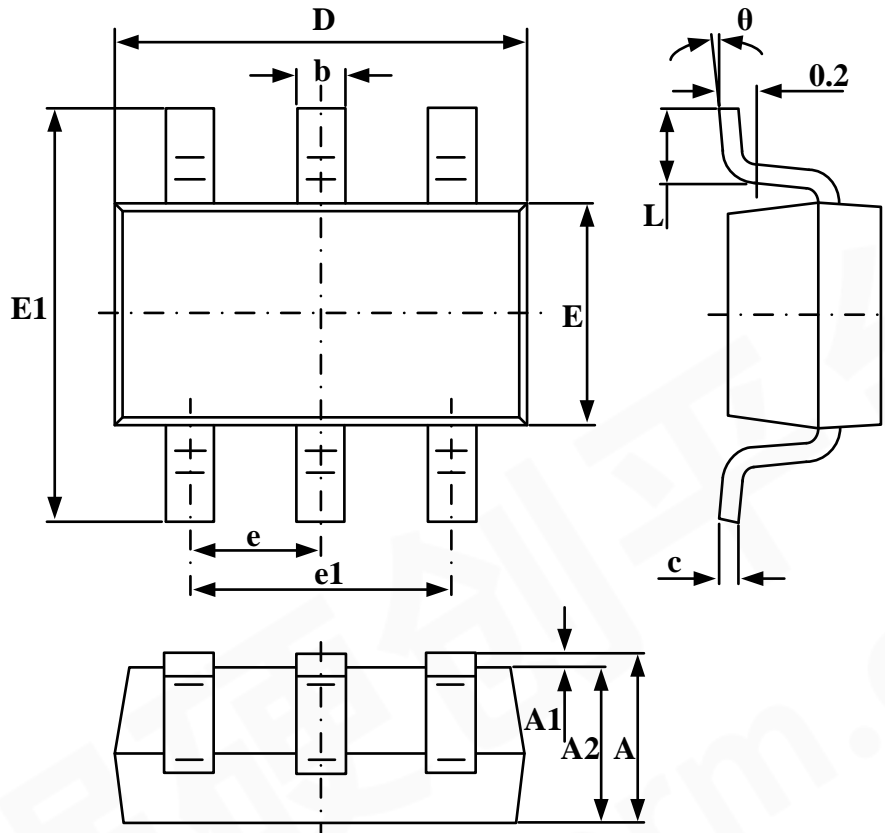

Symbol	Dimensions (mm)		Symbol	Dimensions (mm)	
	Min	Max		Min	Max
A	1.050	1.250	e1	1.800	2.000
A1	0.000	0.130	D	2.820	3.020
A2	1.050	1.150	E	1.500	1.720
b	0.300	0.500	E1	2.650	3.000
c	0.100	0.200	L	0.300	0.600
e	0.950 (BSC)		θ	0°	8°

Ordering information

Orderable device	Package type	Package Qty			Device marking	Note
		Tube (Tape & Reel)	Box	Case		
<u>ICF CP2021 DITUG</u>	DIP-8 Green	50 Tube	2000	20000	CP2021	
<u>ICF CP2021 SOTUG</u>	SOP-8 Green	100 Tube	20000	100000	CP2021	
<u>ICF CP2021 SORRG</u>	SOP-8 Green	2500 Tape & Reel	5000	50000	CP2021	
<u>ICF CP2021 S6RRG</u>	SOT-23-6L Green	3000 Tape & Reel	30000	120000	21	

All information is for reference only. It is subject to change without prior notice.